

SUBMERSIBLE PUMPING SYSTEMS



Franklin Fueling Systems



PRODUCT CATALOG

Submersible Pumping Systems

Franklin Fueling Systems has contributed many innovative product designs to the petroleum industry, including the highest performing submersible pumping systems available. Franklin Fueling Systems offers 2 hp and 4 hp models to meet the needs of high volume retailers and variable speed technology provides constant flow during peak business times, as well as efficiencies during off peak times. The innovative MagShell™ design is an expanded motor shell option which increases the flow around the motor by 45%, resulting in significantly higher flow rates. For those high-volume dispensing sites, FFS also offers either a 3 or 5 hp high capacity pump. Intelligent pump controllers, like the STP-SCI smart controller and the MagVFC™ variable frequency controller, provide unmatched user interface and fault detection capabilities to keep your station running.

Submersible Turbine Pumps	2	Submersible Turbine Pump Accessories	31
Submersible Turbine Pump Ordering Guide	5	Submersible Turbine Pump Repair Parts	32
Variable Speed Submersible Turbine Pump Specifications	6	High Capacity Submersible Turbine Pumps	36
Intelligent Submersible Turbine Pumps	9	High Capacity Pump Ordering Guide	38
Fixed Speed Submersible Turbine Pumps	12	High Capacity Line Leak Detector	42
2 hp Specifications	13	High Capacity Pump Controllers	44
1 ½ hp Specifications	16	Three-Phase Smart Controller	44
1/3 and 3/4 hp Specifications	19	STP-CB 3/5 Magnetic Starter	46
Fixed Length Specifications	22	High Capacity Pump Repair Parts	47
Mechanical Line Leak Detector	24		
Submersible Turbine Pump Controllers	26		
Single-Phase Smart Controller	26		
Dispenser Hook Isolation	28		
Single-Phase Control Box	30		

Submersible Turbine Pumps

Since the mid-1950s, Franklin Electric, the parent company of Franklin Fueling Systems, has been involved in the design and manufacture of submersible motors for use in pumping liquids. Building on this extensive history, FFS has contributed innovative product designs for submersible pumps into the twenty-first century. Marketers concerned about fueling times, efficiency, serviceability, reliability and overall quality find it an easy choice to specify FE Petro products from FFS.

Consider these unique FE Petro product features to improve the profitability of your retail operations:



Faster Fueling

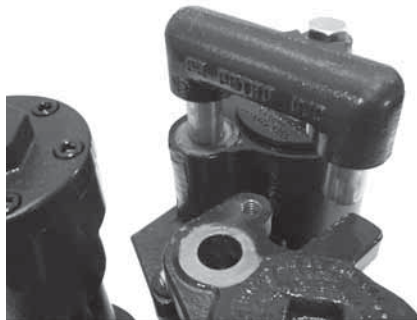

Safety and Ease of Maintenance

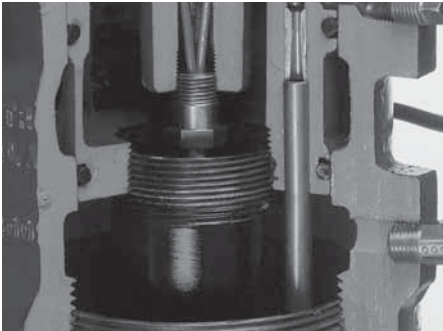

Active Air Eliminator



Simple Service

Advantages

Faster Fueling Times - With innovations like MagShell™, FE Petro products set the standard for submersible pump performance.

Active Air Eliminator - FE Petro products come standard with active air elimination, which eliminates air through the highest point in the pump head at all times when the pump is running, assuring air does not pass into discharge piping.

Safety and Ease of Maintenance - FE Petro STPs include a contractor electrical disconnect, which requires loosening only one bolt, allowing motor wiring to be disconnected without venting the dangerous tank vapors into the sump when servicing FE Petro submersible products.

Simple Servicing - If ever required, the pump can be easily removed from the tank by unthreading three bolts. There is no need to disconnect the syphon system or to remove the leak detector from the system to service the STP.

Advantages

Manual Pressure Relief - A standard FE Petro feature. A vent screw is provided to bleed line pressure to zero when necessary. By turning this screw, product is diverted back to the tank, dropping line pressure to zero. This reduces fuel discharged into the sump manhole or dispenser pan during servicing, further protecting service technicians and the environment.

Reliable Check Valve - The STP uses FE Petro's proven line check valve. At 2 $\frac{3}{4}$ " in diameter, this valve reduces pressure loss at high flow rates resulting in faster fueling times.

Variable Length - The VL2 pump fits 94% of all known tank diameters and tank bury depth combinations. The VL1 and VL3 are available to handle installations shorter or longer than this range. The telescoping connection is a patented FE Petro feature. Pump length can be set by making one simple measurement and setting the pump length without affecting the UL listing of the pump.

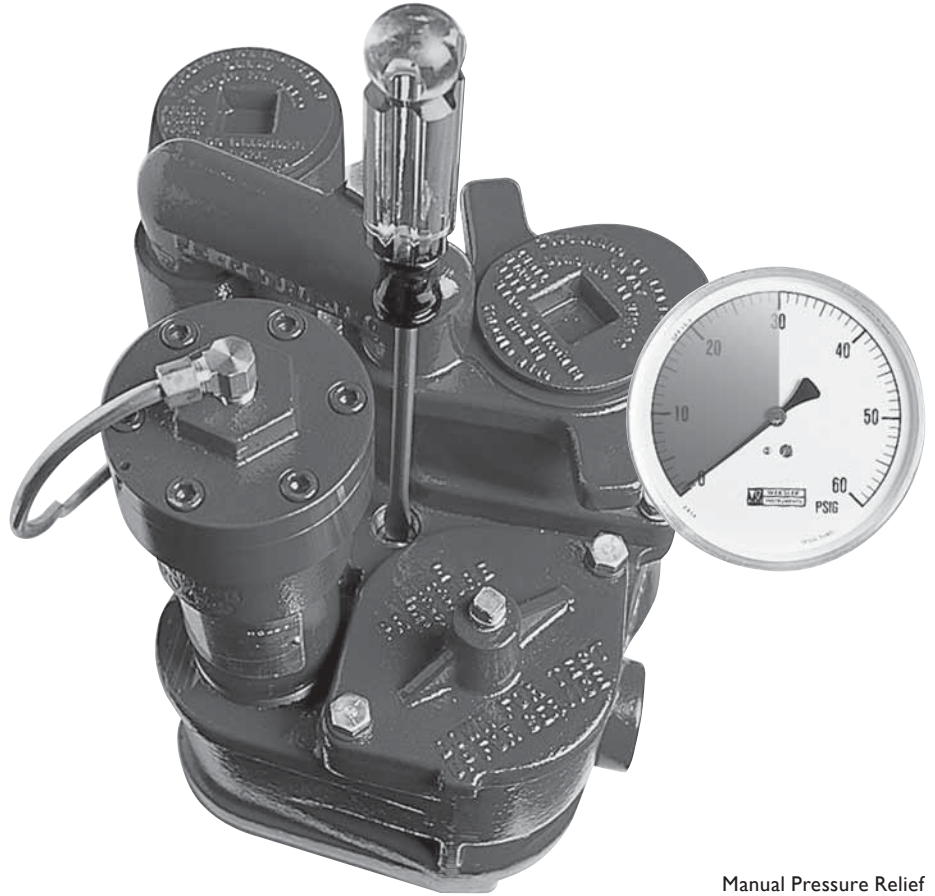

Manual Pressure Relief

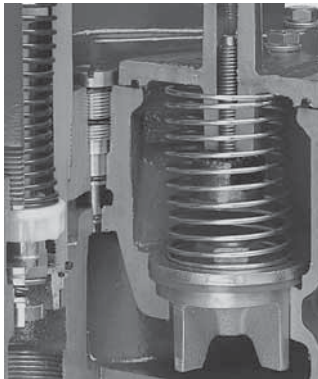

Reliable Check Valve



Variable Length

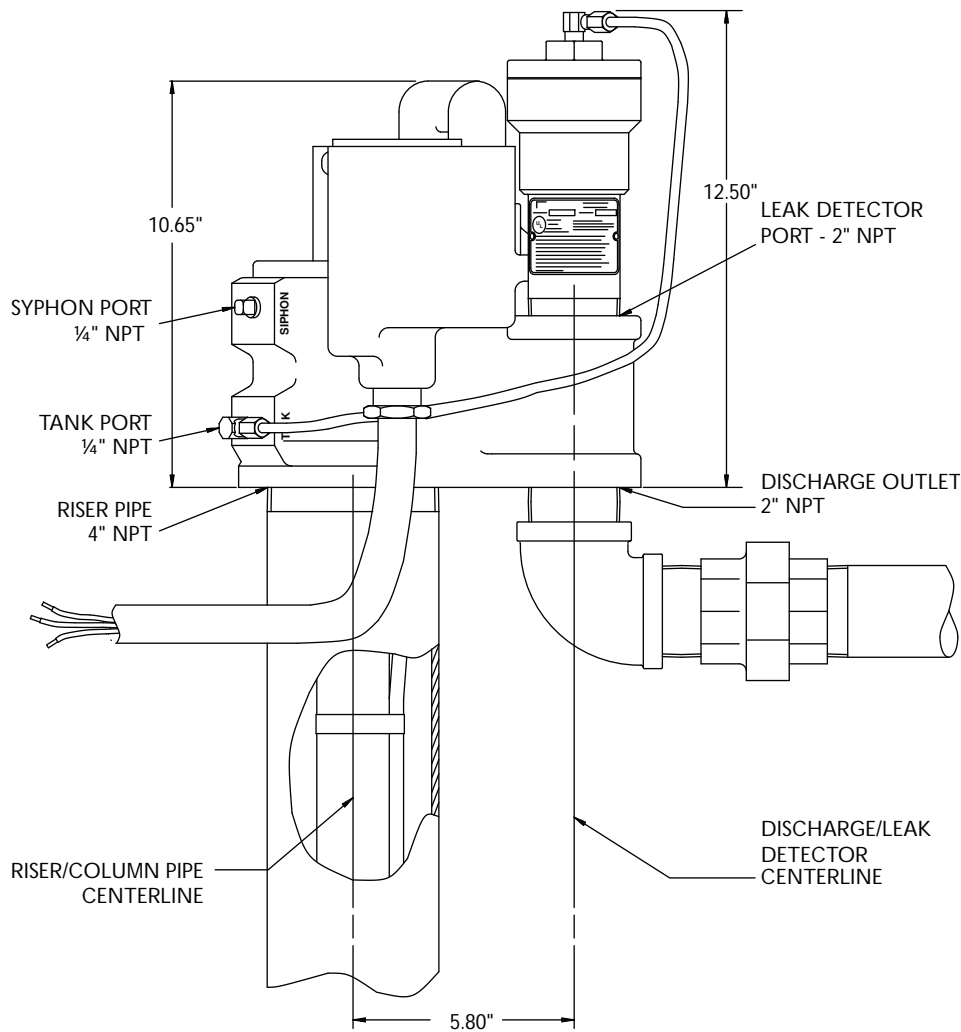
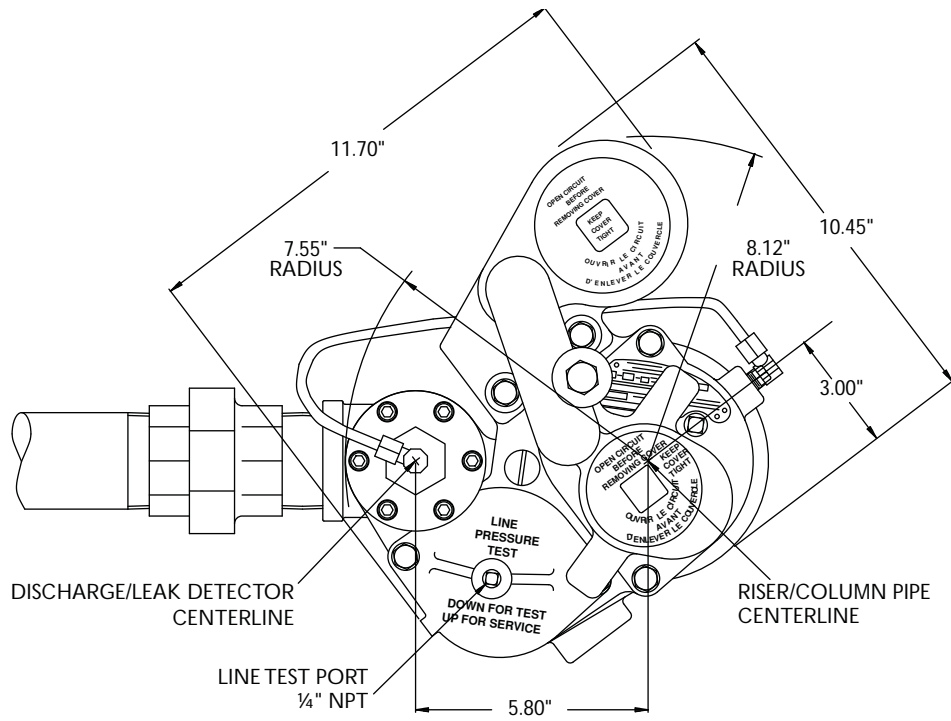

Submersible Turbine Pump Ordering Guide

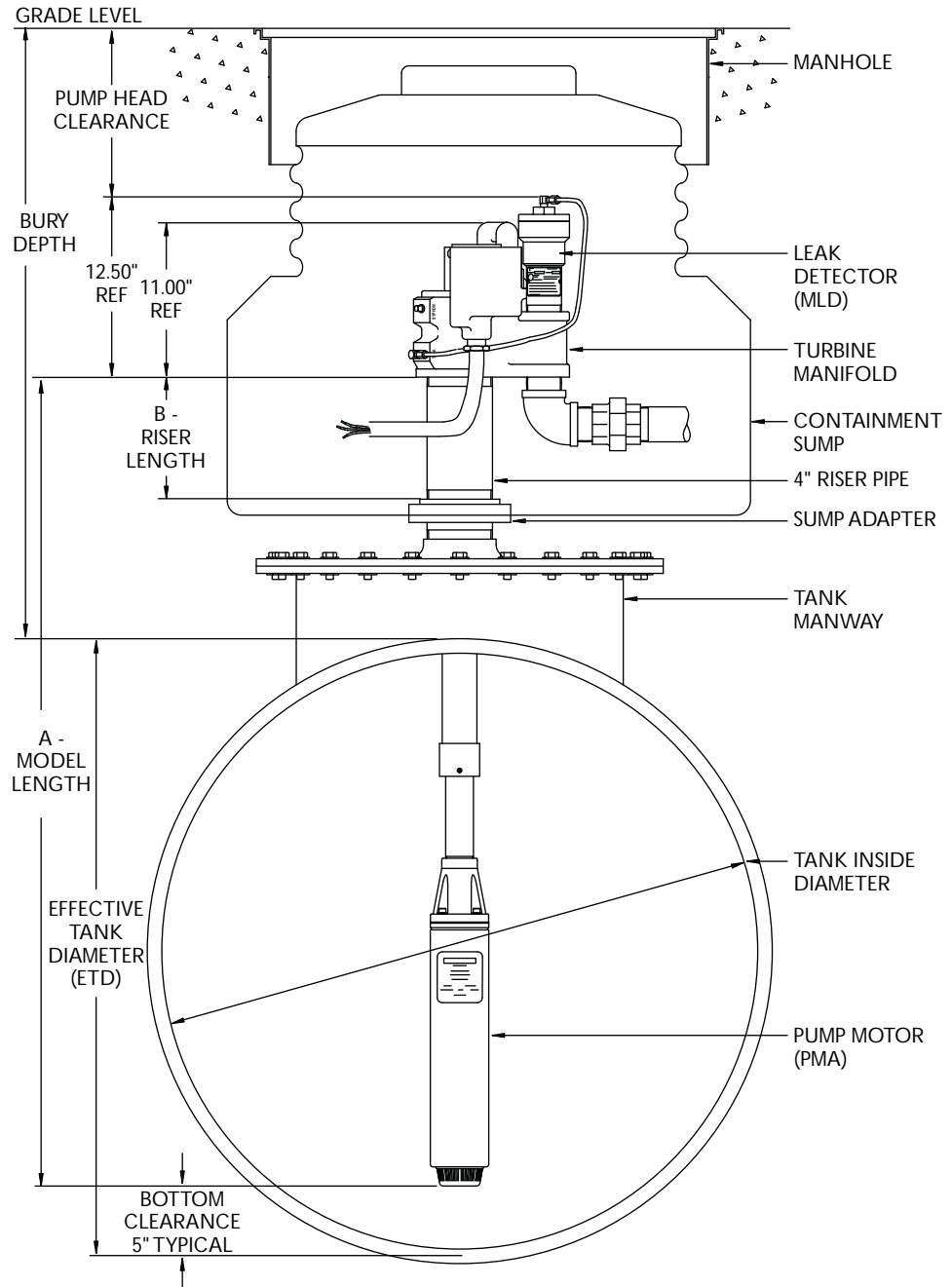

- Notes:
1. Effective tank diameter (ETD) = Inside tank diameter (to top of 4" bung), including tank manway and/or sump adapter.
 2. Model length (A) = ETD plus riser length minus bottom clearance minus 1" thread engagement.
 3. Riser length (B) = Bury depth (to top of tank) minus pump head clearance minus tank manway and/or minus sump adapter.

Variable Speed Submersible Turbine Pump Specifications

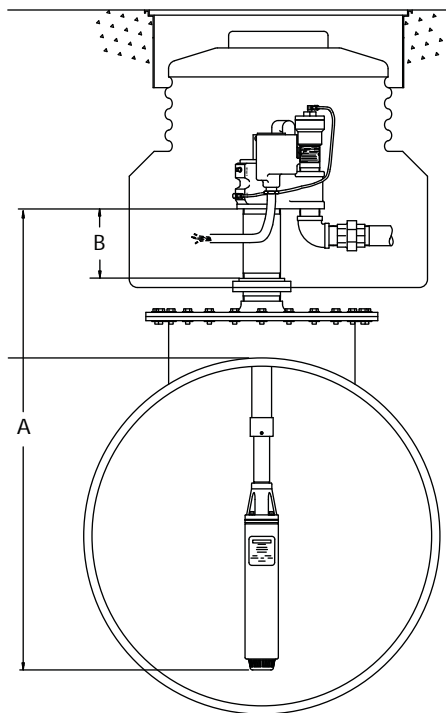

For full diagram see page 5.

Power Requirements

VS models can only be powered by a MagVFC™ controller:

- VS2 models can operate with single- or three-phase incoming power supply to the MagVFC™.
- VS4 models require three-phase incoming power supply to the MagVFC™ for proper operation.
- Incoming power supply to the MagVFC™ can be 200-250 VAC, 50 or 60 Hz.
- MagVFC™ outputs a three-phase, variable frequency signal, valid for FE Petro variable speed pumps only.
- VS2 max. motor draw: 9 Amps.
- VS4 max. motor draw: 15 Amps.
- MagVFC™ max. line draw: 20 Amps.

Pump Motor

- 2 hp or 4 hp, variable speed, two-stage centrifugal type pump motor with integral, automatic, thermal overload protection.
- Max. flow: VS2 = 110 gpm, VS4 = 140 gpm.
- Max. pressure: selectable operating pressure on MagVFC™ between 24 psi and 42 psi deadhead.
- Available with MagShell™ which results in 45% increased flow area around motor.

Liquid Compatibility

- Max. liquid viscosity: 70 SSU at 60 °F (15 °C).
- Variable speed models are UL and cUL listed for fuel mixtures containing up to 15% ethanol or methanol, and 20% MTBE, 20% ETBE or 17% TAME with gasoline.
- Variable speed (non-AG) models can also be used with diesel fuels, fuel oils, kerosene, Avgas and jet fuels in a non-gelled pourable state.
- All wetted elastomers are made of a high grade, fluorocarbon Viton® compound.

Standard Features

- Variable speed models are available in variable and fixed length options.
- Check valve: 2¾" diameter fluorocarbon Viton® seal constructed on cast aluminum body and steel backing washer.
- Pressure relief valve: available in four pressure relief settings, integral to check valve. Standard model relieves at 40 psi and resets above 35 psi.
- Syphon: venturi-type syphon primer supplied with every submersible. Syphon check valve and secondary syphon sold separately.
- Air eliminator: every submersible includes a tank return path with one-way check valve to provide active air elimination.
- Electrical disconnect: electrical yoke for positive contractor disconnect during service.

Approvals

- Consult factory for applicable approvals.

Quality Certification

- Franklin Fueling Systems is an ISO 9001 Certified Manufacturer.
- *Viton® is a registered trademark of DuPont Dow Elastomers.



Variable Speed Submersible Turbine Pump Model Designation System

A typical turbine model designation has up to five components to define the pump being supplied as follows:

STP XXXXX Y - A - B

STP = Basic Model Designation

Note: All STP models include alcohol-gasoline compatibility, variable speed and variable length as part of the base model.

XXXXX = Factory Installed Options

STP model designations may include one or more of the following characters in alphabetical order:

F = Floating suction adapter (1½" NPT female adapter)

K = Intake filter screen (IFS, factory installed to PMA)

M = MagShell™ (flow enhancing, expanded PMA shell)

*R = Model R check valve (24 psi relief/22 psi reset for PLLD)

*W = Model W check valve (16 psi relief/13 psi reset for PPM4000)

*Note: If not otherwise specified, all STP models are supplied with standard model check valve (40 psi relief/35 psi reset for MLD and TS-LS300).

Y = Pump Motor Horsepower Rating

VS2 = 2 hp variable speed

VS4 = 4 hp variable speed

A = Model Length

VL1 = Variable length range #1.

VL2 = Variable length range #2.

VL3 = Variable length range #3.

Note: VL2 models fit 94% of all known installations.

B = Riser Pipe Length

Riser pipe length is expressed as two numeric characters that indicate the total length of the riser in inches. Riser pipes are available from 7" to 69" in 1" increments (additional charge for risers 31" or longer).

2 hp Variable Speed Turbine Performance Chart

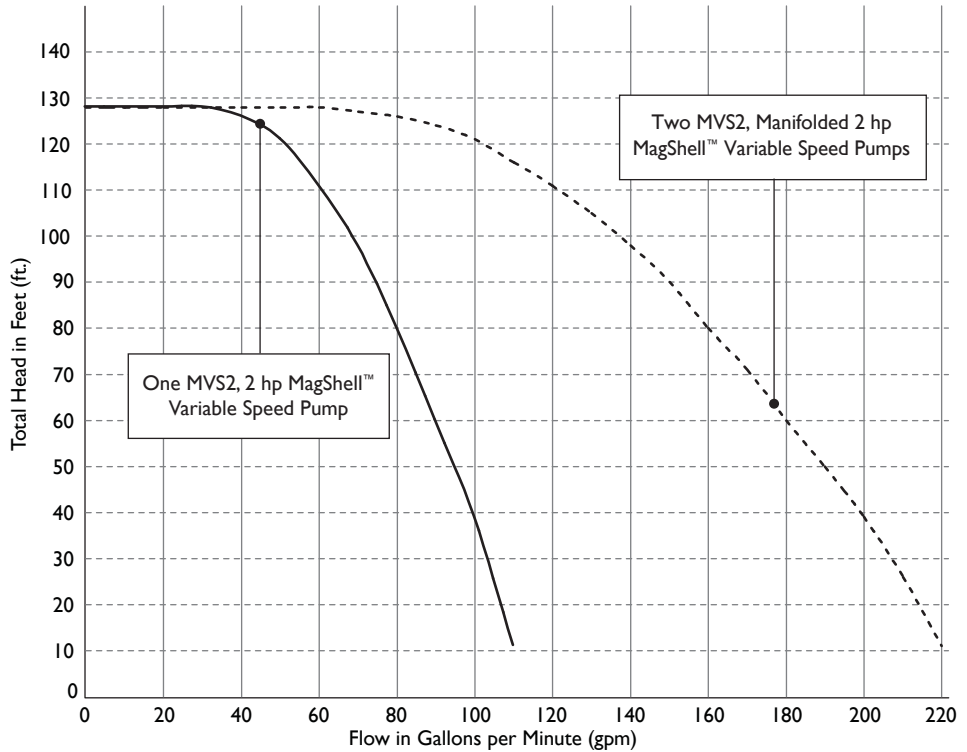

Note: Performance based on pumping gasoline (0.76 specific gravity). Pressure is taken at the manifold discharge outlet. ISTM and STPMVS2 turbines can only be powered by a MagVFC™ with single- or three-phase incoming power.

4 hp Variable Speed Turbine Performance Chart

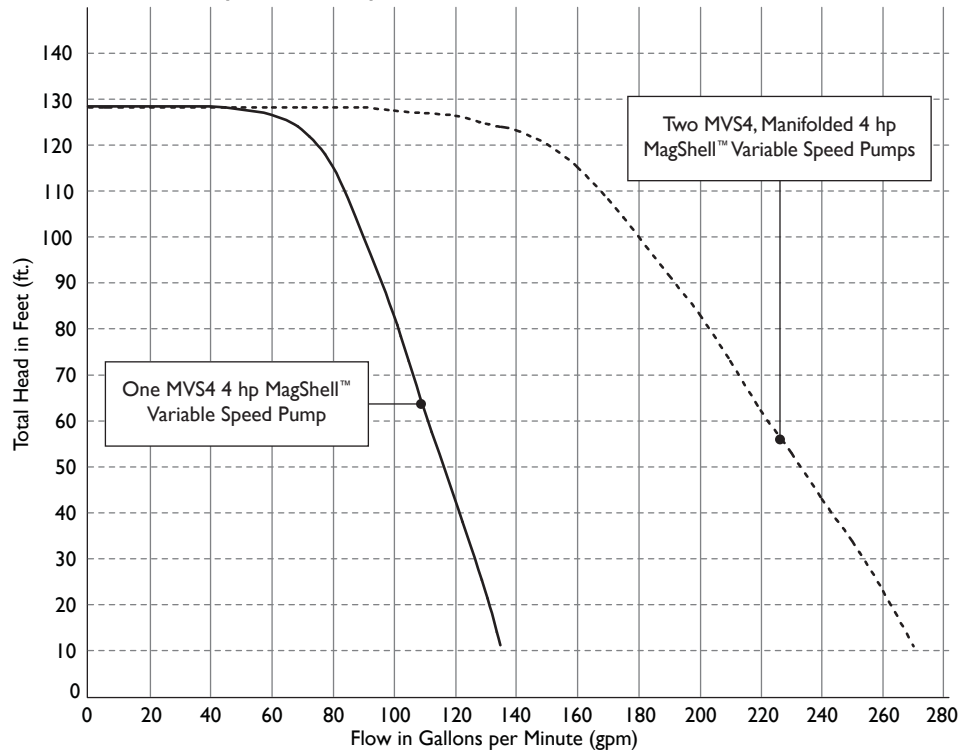

Note: Performance based on pumping gasoline (0.76 specific gravity). Pressure is taken at the manifold discharge outlet. ISTMVS4 and STPMVS4 turbines can only be powered by a MagVFC™ with three-phase incoming power.

Variable Speed Submersible Turbine Pumps (variable speed, variable length)

Model	Description	Model Length Range Number	Model Length* Range
STPMVS2-VL1	2 hp variable speed with MagShell™	VL1	59"-87"
STPMVS2-VL2	2 hp variable speed with MagShell™	VL2	90"-151"
STPMVS2-VL3	2 hp variable speed with MagShell™	VL3	122"-213"
STPMVS4-VL1	4 hp variable speed with MagShell™	VL1	64"-92"
STPMVS4-VL2	4 hp variable speed with MagShell™	VL2	95"-156"
STPMVS4-VL3	4 hp variable speed with MagShell™	VL3	127"-218"

- Notes:
1. Remove "M" from model number for non-MagShell™ pump motor assembly.
 2. All above models are UL and cUL listed for compatibility with fuel mixtures containing up to 15% ethanol or methanol with gasoline, diesel fuels, and 20% MTBE, 20% ETBE or 17% TAME with gasoline.
 3. All models are supplied with a standard check valve unless factory option "R" or "W" is specified.
 4. All above models can only be powered by a MagVFC™. 4 hp models require three-phase incoming power supply, 2 hp models can be supplied with single- or three-phase incoming power.
 5. 4" riser pipe, if supplied locally, must be 4½" OD by 3/16" WT tubing.
 6. For riser pipe lengths 31" to 69", adder charge applies.

*Model length (A) defined as the dimension from turbine manifold bottom to pump motor inlet.

**4" riser pipe, if supplied locally, must be 4½" OD by 3/16" WT tubing.

***For riser pipe lengths 31" to 69", adder charge applies.

Factory Installed Options (specified in model number at time of STP order)

Designation	Description
F	Floating suction adapter, 1½" NPT female, must be factory installed
K	IFS (intake filter screen) factory assembled to pump motor assembly
R	Model R check valve, factory installed, for Veeder Root PLLD Line Leak
W	Model W check valve, factory installed, for Red Jacket PPM4000 Line Leak

Field Installed Options (intelligent submersible turbine pump specific accessories)

Part Number	Description
5874202800	MagVFC™, 2 hp or 4 hp variable frequency controller, one required per IST
400137908	Syphon check valve, alcohol-gasoline compatible (when ordered with IST)
402459931	Model 65 psi check valve (for slave of manifolded ISTs with Veeder Root PLLD)
402507930	Secondary syphon kit (when two syphon primes are required for one IST)

Variable Speed Conversion Kits

Part Number	Description
402671901	Kit with 4 hp variable speed non-MagShell™ (PMA VS4)
400693901	Kit with 2 hp variable speed non-MagShell™ (PMA VS2)

Note: Kits include variable speed pump motor assembly, MagVFC™ variable frequency controller, four-wire contractor's plug and installation instructions.



Advantages

Constant Flow - Depending on peak business requirements, marketers now have a choice of either 2 hp or 4 hp variable speed models. 2 hp provides constant 10 gpm (38 lpm) for up to eight fueling positions operating simultaneously, 4 hp for up to 12 positions.

MagVFC™ Design Highlights - The MagVFC™ features a dual seven segment display to show diagnostic faults. A serial interface is standard to connect to INCON System Sentinel™ software for remote reporting of pump alarms and sharing other pump/ATG intelligence. The MagVFC™ detects and displays these system conditions:

- Dry tank (initiates an immediate pump shut-down).
- Continuous pump run.
- Low incoming voltage.
- Pump motor failure.
- Short circuit detection.
- Controller faults.
- Open circuit detection.

For reduced installation cost, a shielded power cable is not required. Pump protection extends pump life and extended run fault alerts a condition that may render line leak detection ineffective. Remote reporting of pump alarms and sharing of IST and ATG intelligence further reduce station operating costs.

Meets EPA Spitback Control - The IST can be adjusted at installation to perform at maximum per nozzle flow rate of 10 gpm (38 lpm) based on the specifications of your piping and dispensing system. This eliminates overpressuring the system, which results in an unnecessarily high hydraulic hammer and need for other control devices.

Intelligent Submersible Turbine Pumps

FE Petro introduced the first variable speed submersible pump for the petroleum industry in 1995. Since that time, high volume marketers around the world have realized the benefits of filling cars faster during peak business periods that only variable speed submersibles can deliver. Station size and volumes have continued to grow. To meet the needs of these high volume retailers, FE Petro offers the intelligent submersible turbine pump, the industry's highest performing 4" diameter submersible pump.



Constant Flow



Spitback Control



MagVFC™

Intelligent Submersible Turbine Pump Specifications

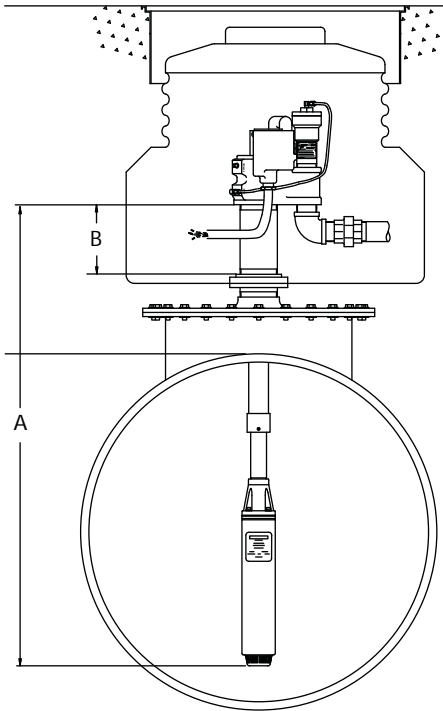

For full diagram see page 5.

Power Requirements

IST models can only be powered by a MagVFC™ controller:

- 2 hp models can operate with single- or three-phase incoming power supply to the MagVFC™.
- 4 hp models require three-phase incoming power supply to the MagVFC™ for proper operation.
- Incoming power supply to the MagVFC™ can be 200-250 VAC, 50 or 60 Hz.
- MagVFC™ outputs a three-phase, variable frequency signal, valid for FE Petro variable speed pumps only.
- 2 hp max. motor draw: 9 Amps.
- 4 hp max. motor draw: 15 Amps.
- MagVFC™ max. line draw: 20 Amps.

Pump Motor

- 2 hp or 4 hp, variable speed, two-stage centrifugal type pump motor with integral, automatic, thermal overload protection.
- Max. flow: 2 hp = 110 gpm, 4 hp = 140 gpm.
- Max. pressure: selectable operating pressure on MagVFC™ between 24 psi and 42 psi deadhead.
- Available with MagShell™, which results in 45% increased flow area around motor.

Liquid Compatibility

- Max. liquid viscosity: 70 SSU at 60 °F (15 °C).
- IST models imply alcohol-gasoline compatibility for fuel mixtures containing up to 100% ethanol or methanol, and 20% MTBE, 20% ETBE or 17% TAME with gasoline.
- IST models can also be used with diesel fuels, fuel oils, kerosene, Avgas and jet fuels in a non-gelled pourable state.
- All wetted elastomers are made of a high grade, fluorocarbon Viton® compound.

Standard Features

- All IST models include variable speed, variable length options and alcohol-gasoline compatibility.
- Check valve: 2¾" diameter fluorocarbon Viton® seal constructed on cast aluminum body and steel backing washer.
- Pressure relief valve: available in four pressure relief settings, integral to check valve. Standard model relieves at 40 psi and resets above 35 psi.
- Syphon: venturi-type syphon primer supplied with every submersible. Syphon check valve and secondary syphon sold separately.
- Air eliminator: every submersible includes tank return path with one-way check valve to provide active air elimination.
- Electrical disconnect: electrical yoke for positive contractor disconnect during service.

Approvals

- Consult factory for applicable approvals.

Quality Certification

- Franklin Fueling Systems is an ISO 9001 Certified Manufacturer.
- *Viton® is a registered trademark of DuPont Dow Elastomers.



Intelligent Submersible Turbine Pump Model Designation System

A typical turbine model designation has up to five components to define the pump being supplied as follows:

IST XXXXX Y - A - B

IST = Basic Model Designation

Note: All IST models include the options of alcohol-gasoline compatibility, variable speed and variable length as part of the base model.

XXXXX = Factory Installed Options

IST model designations may include one or more of the following characters in alphabetical order:

F = Floating suction adapter (1½" NPT female adapter)

K = Intake filter screen (IFS, factory installed to PMA)

M = MagShell™ (flow enhancing, expanded PMA shell)

R* = Model R check valve (24 psi relief/22 psi reset for PLLD)

W* = Model W check valve (16 psi relief/13 psi reset for PPM4000)

*Note: If not otherwise specified, all IST models are supplied with standard model check valve (40 psi relief/35 psi reset for MLD and TS-LS300).

Y = Pump Motor Horsepower Rating**

VS4 = 4 hp variable speed

**Note: If not otherwise specified, 2 hp variable speed is implied.

A = Model Length

1 = 2 hp variable length, 59"-87"

2 = 2 hp variable length, 90"-151"

3 = 2 hp variable length, 122"-213"

VL1 = 4 hp variable length, 64"-92"

VL2 = 4 hp variable length, 95"-156"

VL3 = 4 hp variable length, 127"-218"

Note: IST-2 and ISTVS4-VL2 models fit 94% of all known installations.

B = Riser Pipe Length

Riser pipe length is expressed as two numeric characters that indicate the total length of the riser in inches. Riser pipes are available from 7" to 69" in 1" increments (additional charge for risers 31" or longer).

Intelligent Submersible Turbine Pumps (variable speed, variable length, AG compatible)

Model	Description	Model Length* Range
ISTM-1	2 hp variable speed with MagShell™	59"-87"
ISTM-2	2 hp variable speed with MagShell™	90"-151"
ISTM-3	2 hp variable speed with MagShell™	122"-213"
ISTMVS4-VL1	4 hp variable speed with MagShell™	64"-92"
ISTMVS4-VL2	4 hp variable speed with MagShell™	95"-156"
ISTMVS4-VL3	4 hp variable speed with MagShell™	127"-218"

- Notes:
1. Remove "M" from model number for non-MagShell™ pump motor assembly.
 2. All above models are compatible with fuel mixtures containing up to 100% ethanol or methanol with gasoline, diesel fuels, and 20% MTBE, 20% ETBE or 17% TAME with gasoline.
 3. All models are supplied with a standard check valve unless factory option "R" or "W" is specified.
 4. All above models can only be powered by a MagVFC™. 4 hp models require three-phase incoming power supply, 2 hp models can be supplied with single- or three-phase incoming power.
 5. 4" riser pipe, if supplied locally, must be 4½" OD by 3/16" WVT tubing.
 6. For riser pipe lengths 31" to 69", adder charge applies.
 7. STPAG models are UL listed for compatibility with fuel mixtures containing up to 85% ethanol with gasoline.

*Model length (A) defined as the dimension from turbine manifold bottom to pump motor inlet.

**4" riser pipe, if supplied locally, must be 4½" OD by 3/16" WT tubing.

***For riser pipe lengths 31" to 69", adder charge applies.

Factory Installed Options (specified in model number at time of IST order)

Designation	Description
F	Floating suction adapter, 1½" NPT female, must be factory installed
K	IFS (intake filter screen) factory assembled to pump motor assembly
R	Model R check valve, factory installed, for Veeder Root PLLD Line Leak
W	Model W check valve, factory installed, for Red Jacket PPM4000 Line Leak

Field Installed Options (intelligent submersible turbine pump specific accessories)

Part Number	Description
5874202800	MagVFC™, 2 hp or 4 hp variable frequency controller, one required per IST
400137908	Syphon check valve, alcohol-gasoline compatible (when ordered with IST)
402459931	Model 65 psi check valve (for slave of manifolded ISTs with Veeder Root PLLD)
402507930	Secondary syphon kit (when two syphon primes are required for one IST)

Variable Speed Conversion Kits (AG compatible)

Part Number	Description
400693905	Kit with AG compatible 2 hp variable speed non-MagShell™ (PMAAGVS2)
400693906	Kit with AG compatible 2 hp variable speed with MagShell™ (PMAAGMVS2)
402671905	Kit with AG compatible 4 hp variable speed non-MagShell™ (PMAAGVS4)
402671906	Kit with AG compatible 4 hp variable speed with MagShell™ (PMAAGMVS4)

Note: Kits include variable speed pump motor assembly, MagVFC™ variable frequency controller, four-wire contractor's plug and installation instructions.

Fixed Speed Submersible Turbine Pumps

FE Petro has contributed innovative product designs for submersible pumps into the twenty-first century. With the introduction of a 2 hp fixed speed submersible pump, FE Petro also introduced the MagShell™ innovation to improve the profitability of retail operations.



2 hp vs. 1½ hp Pump Performance

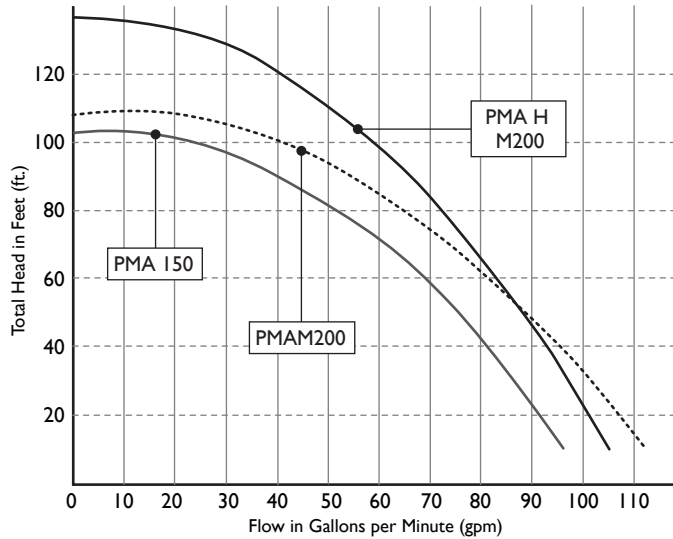

Advantages

Highest Flow - The STPM200 with MagShell™ provides flow rates previously unavailable in 4" fixed speed submersible turbine pumps. One pump can provide good flow rates for up to 10 retail nozzles flowing simultaneously. FE Petro offers the 2 hp performance in both standard and high pressure models to fit any application.

MagShell™ - MagShell™ is a feature on our 2 hp models. The pump motor shell is expanded to increase the flow area around the motor by 45%, resulting in significantly higher flow rates. MagShell™ is constructed of 304 stainless steel and is the highest performing 2 hp fixed speed submersible ever offered.

Faster Fueling Times - FE Petro 1½ and 2 hp turbines fuel cars faster during peak business hours due to the higher pump performance.

Easy Upgrade - If you have existing STPs in your stations and want faster flow rates, consider upgrading to a 2 hp MagShell™ pump motor from FE Petro. The pump motor is compatible with existing FE Petro and competitive-make submersible pumps and can increase flow rates (1 to 2 gpm per nozzle with 5-8 nozzles operating) and go easy on your budget at the same time. FE Petro pump motors sell for about one-third the cost of a complete pump change-out.

2 hp Fixed Speed Submersible Turbine Pump Model Designation System

A typical turbine model designation has up to five components to define the pump being supplied as follows:

STP XXXXX Y - A - B

STP = Basic Model Designation

XXXXX = Factory Installed Options

STP model designations may include one or more of the following characters in alphabetical order:

AG = Alcohol-gasoline compatible (100% ethanol or methanol capable)
 Note: Standard models 0% to 15% ethanol or methanol capable.

F = Floating suction adapter (1½" NPT female adapter)

H = High pressure (45 psi deadhead output)

K = Intake filter screen (IFS, factory installed to PMA)

M = MagShell™ (flow enhancing, expanded PMA shell)

***R** = Model R check valve (24 psi relief/22 psi reset for PLLD)

***W** = Model W check valve (16 psi relief/13 psi reset for PPM4000)

*Note: If not otherwise specified, all STP models supplied with standard model check valve (40 psi relief/35 psi reset for MLD and TS-LS300).

Y = Pump Motor Horsepower Rating

200 = 2 hp fixed speed

A = Model Length

VL1 = Variable length range #1.

VL2 = Variable length range #2.

VL3 = Variable length range #3.

Note: VL2 models fit 94% of all known installations.

B = Riser Pipe Length

Riser pipe length is expressed as two numeric characters that indicate the total length of the riser in inches. Riser pipes are available from 7" to 69" in 1" increments (additional charge for risers 31" or longer).

2 hp Fixed Speed Submersible Turbine Pump Specifications

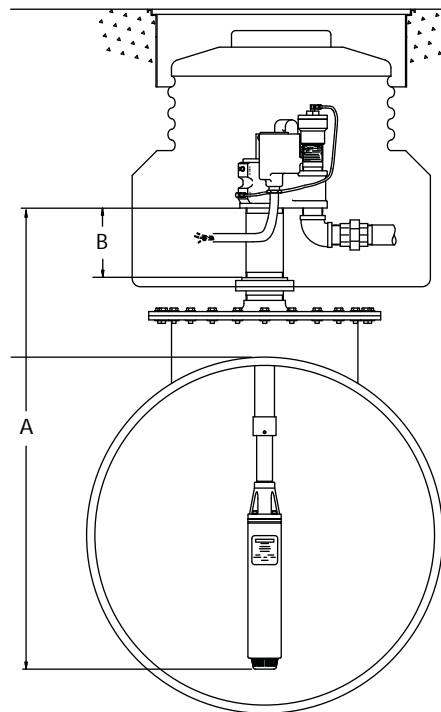

For full diagram see page 5.

Power Requirements

- 2 hp fixed speed models require single-phase, 208-230 VAC, 60 Hz incoming power.
- 2 hp fixed speed models incorporate a starting and running capacitor, with internal bleed resistor, rated 370 Volt, 40 microfarad.
- STP-SCI single-phase smart controllers and STP-CBS single-phase control boxes are available for 2 hp pump control.
- Max. motor draw: 12 Amps.

Pump Motor

- 2 hp fixed speed, 3450 rpm, multi-stage centrifugal type pump motor with integral, automatic, thermal overload protection.
- Standard pressure (two-stage) model, max. flow = 120 gpm, max. pressure = 36 psi.
- High pressure (H200, three-stage) model, max flow = 105 gpm, max. pressure = 45 psi.
- Available with MagShell™ for 45% increased flow area around motor.

Liquid Compatibility

- Max. liquid viscosity: 70 SSU at 60 °F (15 °C).
- Standard STP models are UL and cUL listed for fuel mixtures containing up to 15% ethanol or methanol, and 20% MTBE, 20% ETBE or 17% TAME with gasoline.
- STPAG (AG compatible) models are for fuel mixtures containing up to 100% ethanol or methanol, and 20% MTBE, 20% ETBE or 17% TAME with gasoline.
- 2 hp fixed speed models can also be used with diesel fuels, fuel oils, kerosene, Avgas and jet fuels in a non-gelled pourable state.
- All wetted elastomers are made of a high grade, fluorocarbon Viton® compound.

Standard Features

- 2 hp fixed speed models are available in variable length and fixed length options.
- Check valve: 2¾" diameter fluorocarbon Viton® seal constructed on cast aluminum body and steel backing washer.
- Pressure relief valve: available in four pressure relief settings, integral to check valve. Standard model relieves at 40 psi and resets above 35 psi.
- Syphon: venturi-type syphon primer supplied with every submersible. Syphon check valve and secondary syphon sold separately.
- Air eliminator: every submersible includes a tank return path with one-way check valve to provide active air elimination.
- Electrical disconnect: electrical yoke for positive contractor disconnect during service.

Approvals

- Consult factory for applicable approvals.

Quality Certification

- Franklin Fueling Systems is an ISO 9001 Certified Manufacturer.
- *Viton® is a registered trademark of DuPont Dow Elastomers.



2 hp Fixed Speed Turbine Performance Chart

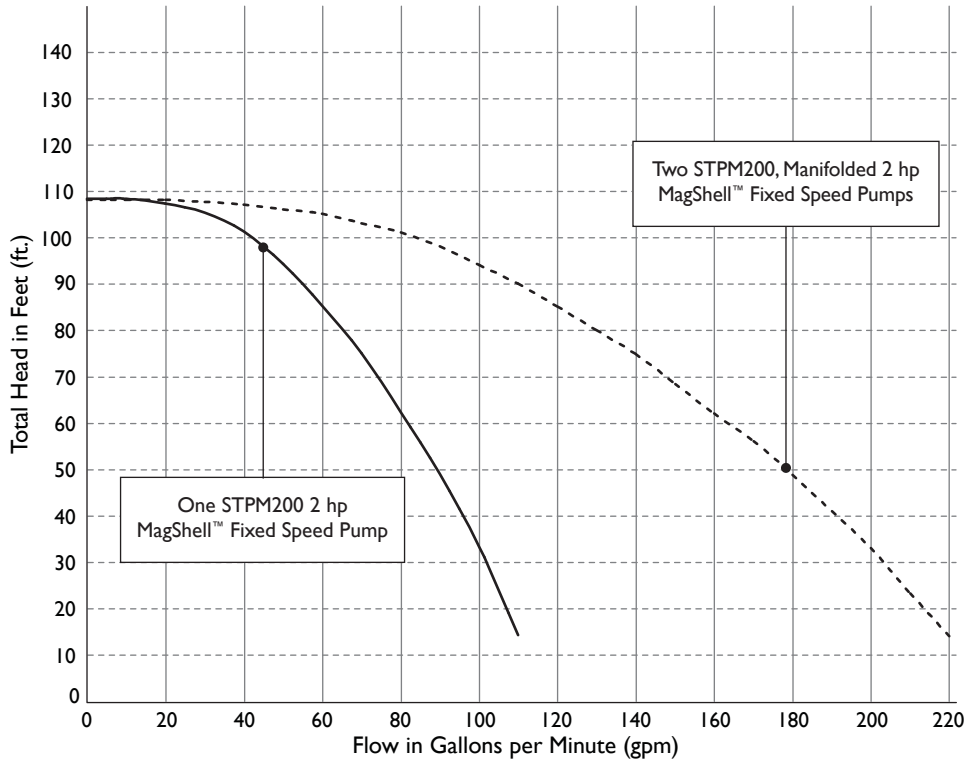

Note: Performance based on pumping solvent (0.78 specific gravity). Pressure is taken at the manifold discharge outlet. STPM200 models are powered by a single-phase, 60 Hz, 208/230 Volt power supply.

2 hp High Pressure Fixed Speed Turbine Performance Chart

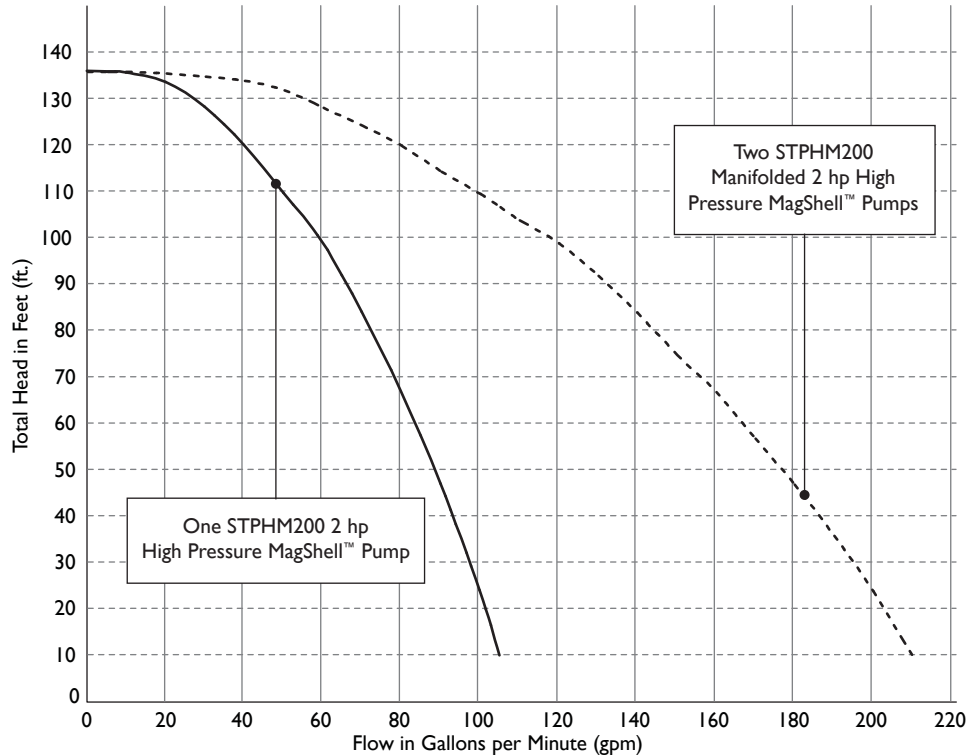

Note: Performance based on pumping solvent (0.78 specific gravity). Pressure is taken at the manifold discharge outlet. STPHM200 models are powered by a single-phase, 60 Hz, 208/230 Volt power supply.



2 hp Fixed Speed Submersible Turbine Pumps

Model	Description	Model Length Range Number	Model Length* Range
STPM200-VL1	2 hp fixed speed with MagShell™	VL1	63"-91"
STPM200-VL2	2 hp fixed speed with MagShell™	VL2	94"-154"
STPM200-VL3	2 hp fixed speed with MagShell™	VL3	126"-217"
STPHM200-VL1	2 hp high pressure fixed speed with MagShell™	VL1	63"-92"
STPHM200-VL2	2 hp high pressure fixed speed with MagShell™	VL2	94"-155"
STPHM200-VL3	2 hp high pressure fixed speed with MagShell™	VL3	126"-218"
Alcohol-Gasoline Model	Description	Model Length Range Number	Model Length* Range
STPAGM200-VL1	2 hp AG fixed speed with MagShell™	VL1	63"-91"
STPAGM200-VL2	2 hp AG fixed speed with MagShell™	VL2	94"-154"
STPAGM200-VL3	2 hp AG fixed speed with MagShell™	VL3	126"-217"
STPAGHM200-VL1	2 hp AG high pressure fixed speed with MagShell™	VL1	63"-92"
STPAGHM200-VL2	2 hp AG high pressure fixed speed with MagShell™	VL2	94"-155"
STPAGHM200-VL3	2 hp AG high pressure fixed speed with MagShell™	VL3	126"-218"

- Notes:
1. Remove "M" from model number for non-MagShell™ pump motor assembly.
 2. STP models are compatible with fuel mixtures containing up to 15% ethanol or methanol with gasoline, and 20% MTBE, 20% ETBE or 17% TAME with gasoline.
STPAG models are compatible with fuel mixtures containing: up to 100% ethanol or methanol with gasoline, and 20% MTBE, 20% ETBE or 17% TAME with gasoline.
 3. All models are supplied with a standard check valve unless factory option "R" or "W" is specified.
 4. All above models require single-phase, 208-230 VAC, 60 Hz incoming power.
 5. 4" riser pipe, if supplied locally, must be 4½" OD by 3/16" WT tubing.
 6. For riser pipe lengths 31" to 69", adder charge applies.
 7. STPAG models are UL listed for compatibility with fuel mixtures containing up to 85% ethanol with gasoline.

*Model length (A) defined as the dimension from turbine manifold bottom to pump motor inlet.

Factory Installed Options

(specified in model number at time of STP order)

Designation	Description
F	Floating suction adapter, 1½" NPT female, must be factory installed
K	IFS (intake filter screen) factory assembled to pump motor assembly
R	Model R check valve, factory installed, for Veeder Root PLLD Line Leak
W	Model W check valve, factory installed, for Red Jacket PPM4000 Line Leak

Field Installed Options

(2 hp fixed speed specific accessories)

Part Number	Description
400137908	Syphon check valve, alcohol-gasoline compatible (when ordered with STP)
400818921	STP-CBS, single-phase control box with lockout switch, 110 Volt coil
402312921	STP-DHI-SCI, combo DHI with factory wired STP-SCI (when purchased with a 4" STP)
402312921	STP-DHI-SCI, combo DHI with factory wired STP-SCI (when purchased without a 4" STP)*
402313921	STP-DHI-CBS, combo DHI with factory wired STP-CBS
402459931	Model 65 psi check valve (for slave of manifolded STPs with Veeder Root PLLD)
402507930	Secondary syphon kit (when two syphon primes are required for one STP)
5800100215	STP-SCI, single-phase smart controller (when purchased without a 4" STP)
5800100215	STP-SCI, single-phase smart controller (when purchased with a 4" STP)*
5800300100	STP-DHI, dispenser hook isolation for 110 Volt dispenser handle switches, up to eight each

*When purchasing STP-SCI or STP-DHI-SCI in equal quantities of fixed speed 4" STPs, the STP-SCI or STP-DHI-SCI will be invoiced at special discount pricing.

1½ hp Fixed Speed Submersible Turbine Pump Specifications

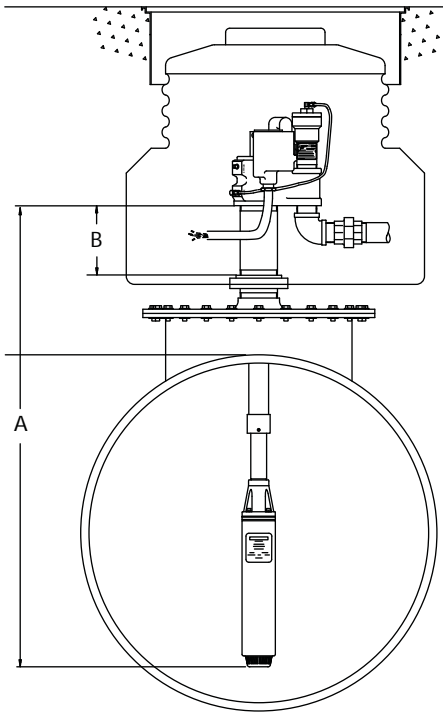

For full diagram see page 5.

Power Requirements

- 1½ hp fixed speed models require single-phase, 208-230 VAC, 60 Hz incoming power.
- 1½ hp fixed speed models incorporate a starting and running capacitor, with internal bleed resistor, rated 370 Volt, 15 microfarad.
- STP-SCI single-phase smart controllers and STP-CBS single-phase control boxes are available for 1½ hp pump control.
- Max. motor draw: 11 Amps.

Pump Motor

- 1½ hp fixed speed, 3450 rpm, multi-stage centrifugal type pump motor with integral, automatic, thermal overload protection.
- Standard pressure (two-stage) model, max. flow = 100 gpm, max. pressure = 34 psi.
- High pressure (H150, three-stage) model, max. flow = 65 gpm, max. pressure = 46 psi.

Liquid Compatibility

- Max. liquid viscosity: 70 SSU at 60 °F (15 °C).
- Standard models are UL and cUL listed for fuel mixtures containing up to 15% ethanol or methanol, and 20% MTBE, 20% ETBE or 17% TAME with gasoline.
- STPAG models are compatible for fuel mixtures containing up to 100% ethanol or methanol, and 20% MTBE, 20% ETBE or 17% TAME with gasoline.
- 1½ hp fixed speed models can also be used with diesel fuels, fuel oils, kerosene, Avgas and jet fuels in a non-gelled pourable state.
- All wetted elastomers are made of a high grade, fluorocarbon Viton® compound.

Standard Features

- 1½ hp fixed speed models are available in variable and fixed length options.
- Check valve: 2¾" diameter fluorocarbon Viton® seal constructed on cast aluminum body and steel backing washer.
- Pressure relief valve: available in four pressure relief settings, integral to check valve. Standard model relieves at 40 psi and resets above 35 psi.
- Syphon: venturi-type syphon primer supplied with every submersible. Syphon check valve and secondary syphon sold separately.
- Air eliminator: every submersible includes a tank return path with one-way check valve to provide active air elimination.
- Electrical disconnect: electrical yoke for positive contractor disconnect during service.

Approvals

- Consult factory for applicable approvals.

Quality Certification

- Franklin Fueling Systems is an ISO 9001 Certified Manufacturer.

*Viton® is a registered trademark of DuPont Dow Elastomers.



1½ hp Fixed Speed Submersible Turbine Pump Model Designation System

A typical turbine model designation has up to five components to define the pump being supplied as follows:

STP XXXXX Y - A - B

STP = Basic Model Designation

XXXXX = Factory Installed Options

STP model designations may include one or more of the following characters in alphabetical order:

AG = Alcohol-gasoline compatible (100% ethanol or methanol capable)
Note: Standard models 0% to 15% ethanol or methanol capable.

F = Floating suction adapter (1½" NPT female adapter)

H = High pressure (46 psi deadhead output)

K = Intake filter screen (IFS, factory installed to PMA)

***R** = Model R check valve (24 psi relief/22 psi reset for PLLD)

***W** = Model W check valve (16 psi relief/13 psi reset for PPM4000)

*Note: If not otherwise specified, all STP models supplied with standard model check valve (40 psi relief/35 psi reset for MLD and TS-LS300).

Y = Pump Motor Horsepower Rating

150 = 1½ hp fixed speed

A = Model Length

VL1 = Variable length range #1.

VL2 = Variable length range #2.

VL3 = Variable length range #3.

Note: VL2 models fit 94% of all known installations.

B = Riser Pipe Length

Riser pipe length is expressed as two numeric characters that indicate the total length of the riser in inches. Riser pipes are available from 7" to 69" in 1" increments (additional charge for risers 31" or longer).

1½ hp Fixed Speed Turbine Performance Chart

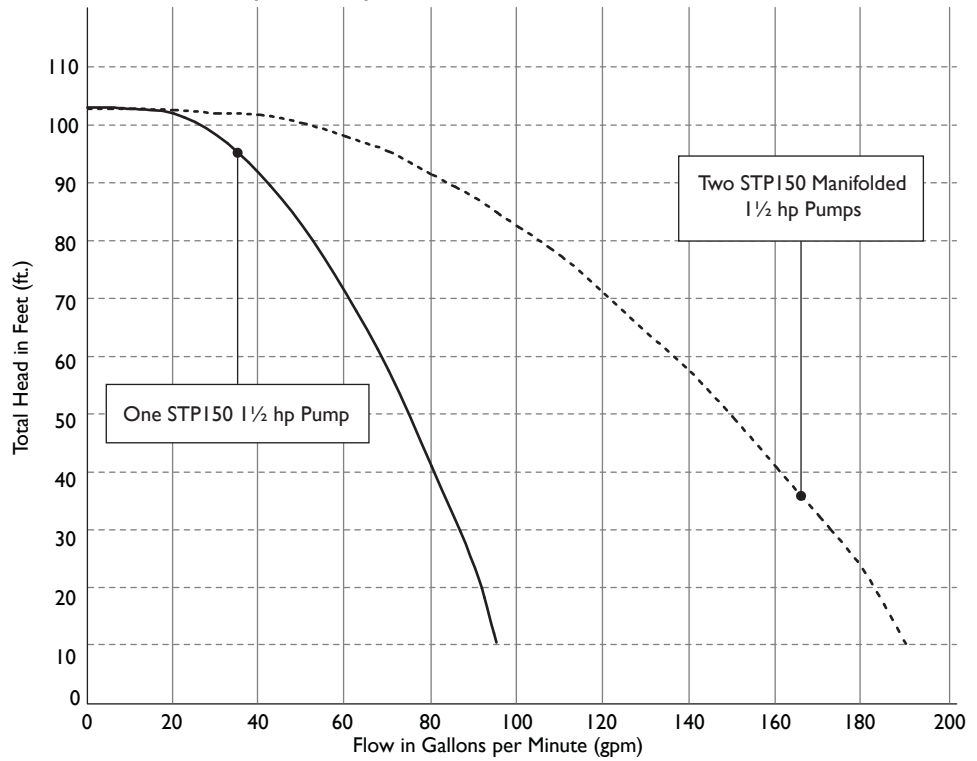

Note: Performance based on pumping solvent (0.78 specific gravity). Pressure is taken at the manifold discharge outlet. STPI50 models are powered by a single-phase, 60 Hz, 208/230 Volt power supply.

1½ hp High Pressure Fixed Speed Turbine Performance Chart

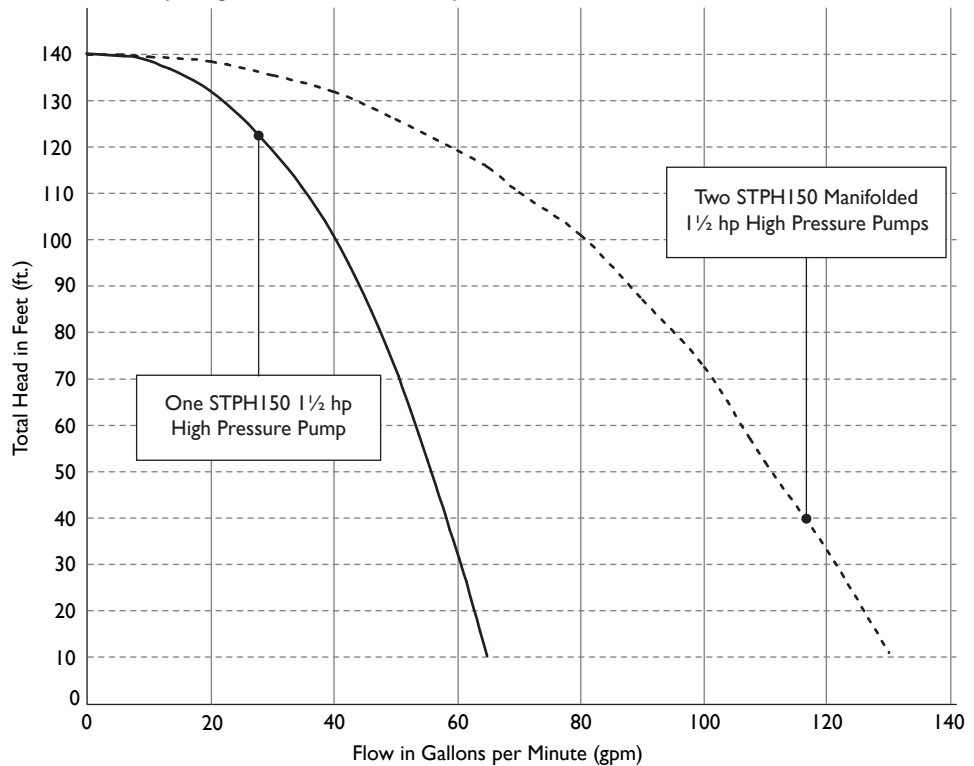

Note: Performance based on pumping solvent (0.78 specific gravity). Pressure is taken at the manifold discharge outlet. STPH150 models are powered by a single-phase, 60 Hz, 208/230 Volt power supply.

1½ HP Fixed Speed Submersible Turbine Pumps

Model	Description	Model Length Range Number	Model Length* Range
STPI50-VL1	1½ hp fixed speed	VL1	60"-88"
STPI50-VL2	1½ hp fixed speed	VL2	91"-152"
STPI50-VL3	1½ hp fixed speed	VL3	123"-214"
STPHI50-VL1	1½ hp high pressure fixed speed	VL1	61"-89"
STPHI50-VL2	1½ hp high pressure fixed speed	VL2	92"-152"
STPHI50-VL3	1½ hp high pressure fixed speed	VL3	124"-215"
Alcohol-Gasoline Model	Description	Model Length Range Number	Model Length* Range
STPAG150-VL1	1½ hp AG fixed speed	VL1	60"-88"
STPAG150-VL2	1½ hp AG fixed speed	VL2	91"-152"
STPAG150-VL3	1½ hp AG fixed speed	VL3	123"-214"
STPAGHI50-VL1	1½ hp AG high pressure fixed speed	VL1	61"-89"
STPAGHI50-VL2	1½ hp AG high pressure fixed speed	VL2	92"-152"
STPAGHI50-VL3	1½ hp AG high pressure fixed speed	VL3	124"-215"

- Notes: 1. STP models are compatible with fuel mixtures containing up to 15% ethanol or methanol with gasoline, and 20% MTBE, 20% ETBE or 17% TAME with gasoline.
 STPAG models are compatible with fuel mixtures containing up to 100% ethanol or methanol with gasoline, and 20% MTBE, 20% ETBE or 17% TAME with gasoline.
- All models are supplied with a standard check valve unless factory option "R" or "W" is specified.
 - All above models require single-phase, 208-230 VAC, 60 Hz incoming power.
 - 4" riser pipe, if supplied locally, must be 4½" OD by 3/16" WT tubing.
 - For riser pipe lengths 31" to 69", adder charge applies.
 - STPAG models are UL listed for compatibility with fuel mixtures containing up to 85% ethanol with gasoline.

*Model length (A) defined as the dimension from turbine manifold bottom to pump motor inlet.

Factory Installed Options

(specified in model number at time of STP order)

Designation	Description
F	Floating suction adapter, 1½" NPT female, must be factory installed
K	IFS (intake filter screen), factory assembled to pump motor assembly
R	Model R check valve, factory installed, for Veeder Root PLLD Line Leak
W	Model W check valve, factory installed, for Red Jacket PPM4000 Line Leak

Field Installed Options

(1½ hp fixed speed specific accessories)

Part Number	Description
400137908	Syphon check valve, alcohol-gasoline compatible (when ordered with STP)
400818921	STP-CBS, single-phase control box with lockout switch, 110 Volt coil
402312921	STP-DHI-SCI, combo DHI with factory wired STP-SCI (when purchased with a 4" STP)
402312921	STP-DHI-SCI, combo DHI with factory wired STP-SCI (when purchased without a 4" STP)*
402313921	STP-DHI-CBS, combo DHI with factory wired STP-CBS
402459931	Model 65 psi check valve (for slave of manifolded STPs with Veeder Root PLLD)
402507930	Secondary syphon kit (when two syphon primes are required for one STP)
5800100215	STP-SCI, single-phase smart controller (when purchased without a 4" STP)
5800100215	STP-SCI, single-phase smart controller (when purchased with a 4" STP)*
5800300100	STP-DHI, dispenser hook isolation for 110 Volt dispenser handle switches, up to eight each

*When purchasing STP-SCI or STP-DHI-SCI in equal quantities of fixed speed 4" STPs, the STP-SCI or STP-DHI-SCI will be invoiced at special discount pricing.

1/3 and 3/4 HP Fixed Speed Submersible Turbine Pump Model Designation System

A typical turbine model designation has up to five components to define the pump being supplied as follows:

STP XXXXX Y - A - B

STP = Basic Model Designation

XXXXX = Factory Installed Options

STP model designations may include one or more of the following characters in alphabetical order:

AG = Alcohol-gasoline compatible (100% ethanol or methanol capable)
 Note: Standard models 0% to 15% ethanol or methanol capable.

F = Floating suction adapter (1 1/2" NPT female adapter)

K = Intake filter screen (IFS, factory installed to PMA)

***R** = Model R check valve (24 psi relief/22 psi reset for PLLD)

***W** = Model W check valve (16 psi relief/13 psi reset for PPM4000)

*Note: If not otherwise specified, all STP models supplied with standard model check valve (40 psi relief/35 psi reset for MLD and TS-LS300)

Y = Pump Motor Horsepower Rating

33 = 1/3 hp fixed speed

75 = 3/4 hp fixed speed

A = Model Length**

VL1 = Variable length range #1.

VL2 = Variable length range #2.

VL3 = Variable length range #3.

Note: VL2 models fit 94% of all known installations.

B = Riser Pipe Length

Riser pipe length is expressed as two numeric characters that indicate the total length of the riser in inches. Riser pipes are available from 7" to 69" in 1" increments (additional charge for risers 31" or longer).

1/3 and 3/4 HP Fixed Speed Submersible Turbine Pump Specifications

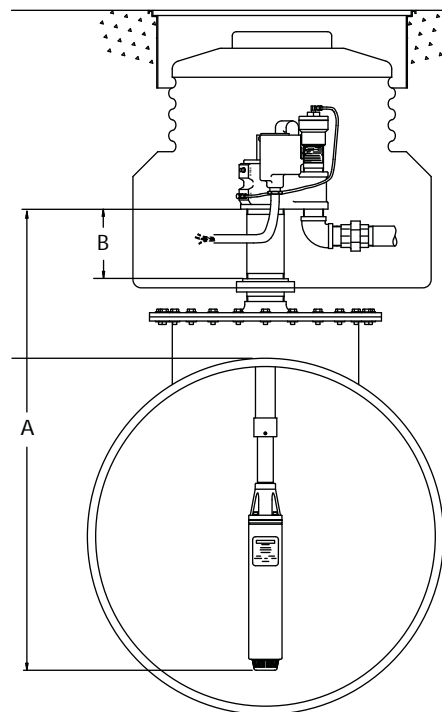

For full diagram see page 5.

Power Requirements

- 1/3 and 3/4 hp fixed speed models require single-phase, 208-230 VAC, 60 Hz incoming power.
- 1/3 and 3/4 hp fixed speed models incorporate a starting and running capacitor, with internal bleed resistor, rated 370 Volt, 15 microfarad.
- STP-SCI single-phase smart controllers and STP-CBS single-phase control boxes are available for 1/3 and 3/4 hp pump control.
- 1/3 hp max. motor draw: 4 Amps.
- 3/4 hp max. motor draw: 7 Amps.

Pump Motor

- 1/3 and 3/4 hp fixed speed, 3450 rpm, two-stage centrifugal type pump motor with integral, automatic, thermal overload protection.
- 1/3 hp models have a max. flow of 40 gpm and a max. pressure of 28 psi.
- 3/4 hp models have a max. flow of 65 gpm and a max. pressure of 31 psi.

Liquid Compatibility

- Max. liquid viscosity: 70 SSU at 60 °F (15 °C).
- Standard models are UL and cUL listed for fuel mixtures containing up to 15% ethanol or methanol, and 20% MTBE, 20% ETBE or 17% TAME with gasoline.
- STPAG models are compatible with fuel mixtures containing up to 100% ethanol or methanol, and 20% MTBE, 20% ETBE or 17% TAME with gasoline.
- 1/3 and 3/4 hp fixed speed models can also be used with diesel fuels, fuel oils, kerosene, Avgas and jet fuels in a non-gelled pourable state.
- All wetted elastomers are made of a high grade, fluorocarbon Viton® compound.

Standard Features

- 1/3 and 3/4 hp fixed speed models are available in variable and fixed length options.
- Check valve: 2 3/4" diameter fluorocarbon Viton® seal constructed on cast aluminum body and steel backing washer.
- Pressure relief valve: available in four pressure relief settings, integral to check valve. Standard model relieves at 40 psi and resets above 35 psi.
- Syphon: venturi-type syphon primer supplied with every submersible. Syphon check valve and secondary syphon sold separately.
- Air eliminator: every submersible includes a tank return path with one-way check valve to provide active air elimination.
- Electrical disconnect: electrical yoke for positive contractor disconnect during service.

Approvals

- Consult factory for applicable approvals.

Quality Certification

- Franklin Fueling Systems is an ISO 9001 Certified Manufacturer.
- *Viton® is a registered trademark of DuPont Dow Elastomers.



1/3 hp Fixed Speed Turbine Performance Chart

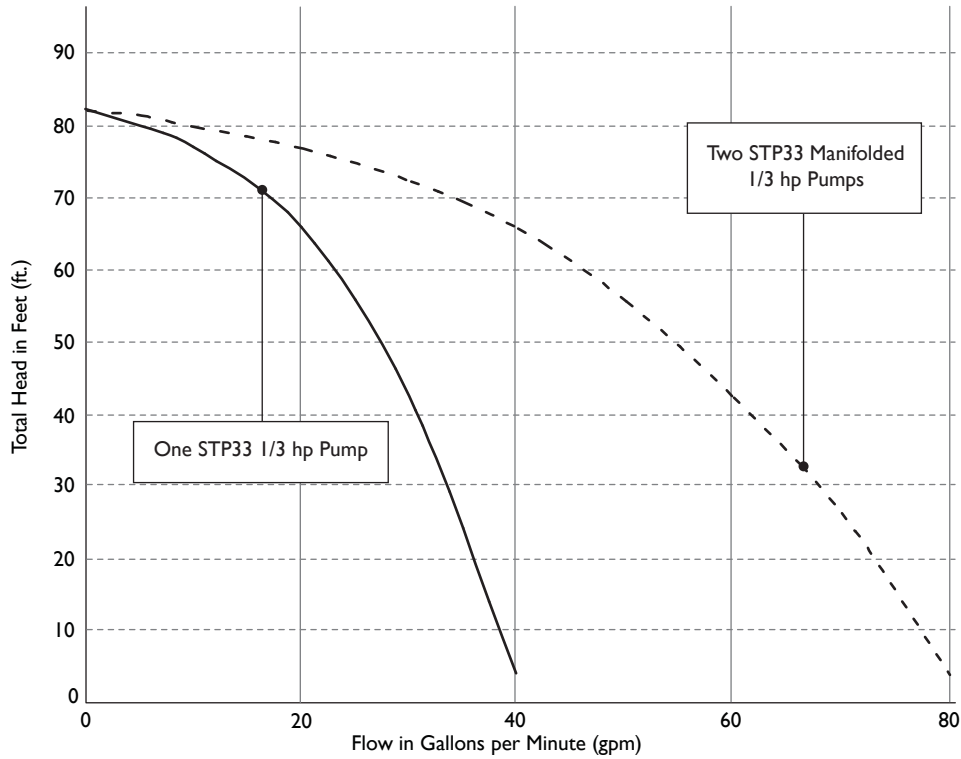

Note: Performance based on pumping solvent (0.78 specific gravity). Pressure is taken at the manifold discharge outlet. STP33 models are powered by a single-phase, 60 Hz, 208/230 Volt power supply.

3/4 hp Fixed Speed Turbine Performance Chart

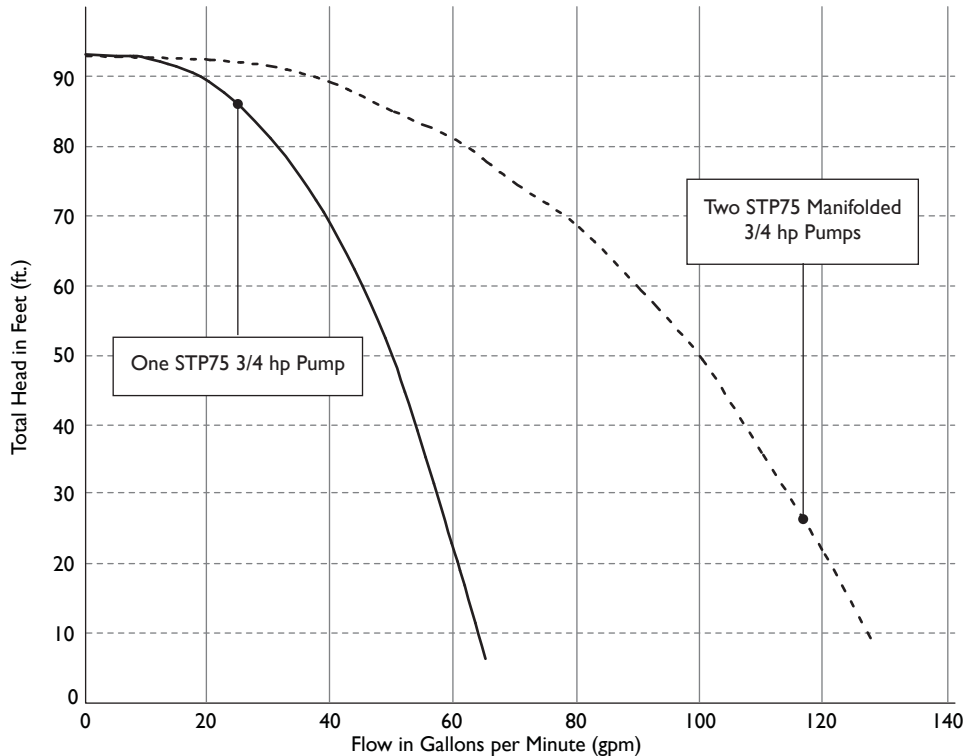

Note: Performance based on pumping solvent (0.78 specific gravity). Pressure is taken at the manifold discharge outlet. STP75 models are powered by a single-phase, 60 Hz, 208/230 Volt power supply.



1/3 and 3/4 HP Fixed Speed Submersible Turbine Pumps

Model	Description	Model Length Range Number	Model Length* Range
STP33-VL1	1/3 hp fixed speed	VL1	55"-83"
STP33-VL2	1/3 hp fixed speed	VL2	86"-147"
STP33-VL3	1/3 hp fixed speed	VL3	118"-209"
STP75-VL1	3/4 hp fixed speed	VL1	57"-86"
STP75-VL2	3/4 hp fixed speed	VL2	88"-149"
STP75-VL3	3/4 hp fixed speed	VL3	120"-212"
Alcohol-Gasoline Model	Description	Model Length Range Number	Model Length* Range
STPAG33-VL1	1/3 hp AG fixed speed	VL1	55"-83"
STPAG33-VL2	1/3 hp AG fixed speed	VL2	86"-147"
STPAG33-VL3	1/3 hp AG fixed speed	VL3	118"-209"
STPAG75-VL1	3/4 hp AG fixed speed	VL1	57"-86"
STPAG75-VL2	3/4 hp AG fixed speed	VL2	88"-149"
STPAG75-VL3	3/4 hp AG fixed speed	VL3	120"-212"

Notes: 1. STP models are compatible with fuel mixtures containing up to 15% ethanol or methanol with gasoline, and 20% MTBE, 20% ETBE or 17% TAME with gasoline.

STPAG models are compatible with fuel mixtures containing up to 100% ethanol or methanol with gasoline, and 20% MTBE, 20% ETBE or 17% TAME with gasoline.

2. All models are supplied with a standard check valve unless factory option "R" or "W" is specified.

3. All above models require single-phase, 208-230 VAC, 60 Hz incoming power.

4. 4" riser pipe, if supplied locally, must be 4 1/2" OD by 3/16" WT tubing.

5. For riser pipe lengths 31" to 69", adder charge applies.

6. STPAG models are UL listed for compatibility with fuel mixtures containing up to 85% ethanol with gasoline.

*Model length (A) defined as the dimension from turbine manifold bottom to pump motor inlet.

Factory Installed Optionsw

(specified in model number at time of STP order)

Designation	Description
F	Floating suction adapter, 1/2" NPT female, must be factory installed
K	IFS (intake filter screen), factory assembled to pump motor assembly
R	Model R check valve, factory installed, for Veeder Root PLLD Line Leak
W	Model W check valve, factory installed, for Red Jacket PPM4000 Line Leak

Field Installed Options

(1/3 and 3/4 hp fixed speed specific accessories)

Part Number	Description
400137908	Syphon check valve, alcohol-gasoline compatible (when ordered with STP)
400818921	STP-CBS, single-phase control box with lockout switch, 110 Volt coil
402312921	STP-DHI-SCI, combo DHI with factory wired STP-SCI (when purchased with a 4" STP)
402312921	STP-DHI-SCI, combo DHI with factory wired STP-SCI (when purchased without a 4" STP)*
402313921	STP-DHI-CBS, combo DHI with factory wired STP-CBS
402459931	Model 65 psi check valve (for slave of manifolded STPs with Veeder Root PLLD)
402507930	Secondary syphon kit (when two syphon primes are required for one STP)
5800100215	STP-SCI, single-phase smart controller (when purchased without a 4" STP)
5800100215	STP-SCI, single-phase smart controller (when purchased with a 4" STP)*
5800300100	STP-DHI, dispenser hook isolation for 110 Volt dispenser handle switches, up to eight each

*When purchasing STP-SCI or STP-DHI-SCI in equal quantities of fixed speed 4" STPs, the STP-SCI or STP-DHI-SCI will be invoiced at special discount pricing.

Fixed Length Submersible Turbine Pump Specifications

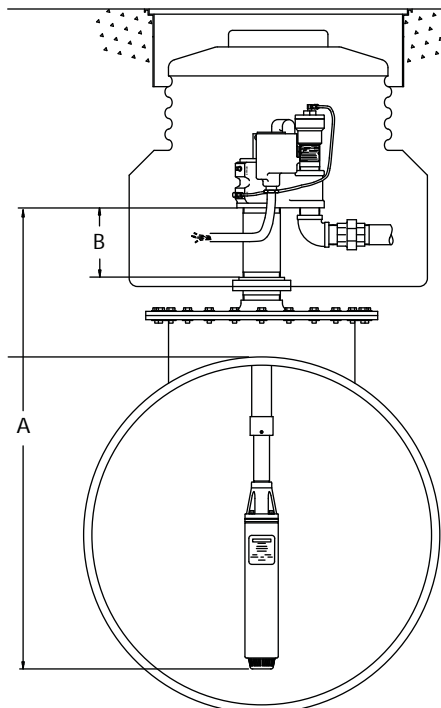

For full diagram see page 5.

Power Requirements

- Fixed length, fixed speed models require single-phase, 208-230 VAC, 60 Hz incoming power.
- Fixed length, fixed speed models are available in 1/3, 3/4, 1 1/2 and 2 hp versions.
- Fixed length, fixed speed models incorporate a starting and running capacitor with internal bleed resistor.
- A 370 Volt, 15 microfarad rated capacitor is used with 1/3, 3/4 and 1 1/2 hp fixed length, fixed speed versions.
- A 370 Volt, 40 microfarad rated capacitor is used with 2 hp fixed length, fixed speed versions.
- STP-SCI single-phase smart controllers and STP-CBS single-phase control boxes are available for fixed speed pump control.

Pump Motor

- Fixed speed, 3450 rpm, multi-stage centrifugal type pump motor with integral, automatic, thermal overload protection.
- 1/3 and 3/4 hp fixed speed models are available as two-stage versions.
- 1 1/2 and 2 hp fixed speed models are available in standard pressure (two-stage) versions and high pressure (H option, three-stage) versions.

Liquid Compatibility

- Max. liquid viscosity: 70 SSU at 60 °F (15 °C).
- Fixed length STP models are UL and cUL listed for fuel mixtures containing up to 15% ethanol or methanol, and 20% MTBE, 20% ETBE or 17% TAME with gasoline.
- AG (alcohol-gasoline) models are compatible with fuel mixtures containing up to 100% ethanol or methanol, and 20% MTBE, 20% ETBE or 17% TAME with gasoline.
- Fixed length models can also be used with diesel fuels, fuel oils, kerosene, Avgas and jet fuels in a non-gelled pourable state.
- All wetted elastomers are made of a high grade, fluorocarbon Viton® compound.

Standard Features

- Check valve: 2 3/4" diameter fluorocarbon Viton® seal constructed on cast aluminum body and steel backing washer.
- Pressure relief valve: available in four pressure relief settings, integral to check valve. Standard model relieves at 40 psi and resets above 35 psi.
- Syphon: venturi-type syphon primer supplied with every submersible. Syphon check valve and secondary syphon sold separately.
- Air eliminator: every submersible includes a tank return path with one-way check valve to provide active air elimination.
- Electrical disconnect: electrical yoke for positive contractor disconnect during service.

Approvals

- Consult factory for applicable approvals.

Quality Certification

- Franklin Fueling Systems is an ISO 9001 Certified Manufacturer.
- *Viton® is a registered trademark of DuPont Dow Elastomers.



Fixed Length Submersible Turbine Pump Model Designation System

A typical turbine model designation has up to five components to define the pump being supplied as follows:

STP XXXXX Y - A - B

STP = Basic Model Designation

XXXXX = Factory Installed Options

STP model designations may include one or more of the following characters in alphabetical order:

AG = Alcohol-gasoline compatible (100% ethanol or methanol capable)
 Note: Standard models 0% to 15% ethanol or methanol capable.

F = Floating suction adapter (1 1/2" NPT female adapter)

H = High pressure (1 1/2 hp and 2 hp models only)

K = Intake filter screen (IFS, factory installed to PMA)

M = MagShell™ (2 hp models only)

*R = Model R check valve (24 psi relief/22 psi reset for PLLD)

*W = Model W check valve (16 psi relief/13 psi reset for PPM4000)

*Note: If not otherwise specified, all STP models supplied with standard model check valve (40 psi relief/35 psi reset for MLD and TS-LS300).

Y = Pump Motor Horsepower Rating

33 = 1/3 hp fixed speed

75 = 3/4 hp fixed speed

150 = 1 1/2 hp fixed speed

200 = 2 hp fixed speed

A = Model Length

Model length is expressed as three numeric characters that indicate the length of the STP from the turbine manifold bottom to the pump motor inlet in inches, available from 37" to 211" (additional charge for models 133" and longer).

B = Riser Pipe Length

Riser pipe length is expressed as two numeric characters that indicate the total length of the riser in inches. Riser pipes are available from 7" to 69" in 1" increments (additional charge for risers 31" or longer).

Fixed Length Submersible Turbine Pumps

Model	Description	Model Length* Range
STP33	1/3 hp fixed speed	37"-132"
STP75	3/4 hp fixed speed	37"-132"
STP150	1 1/2 hp fixed speed	37"-132"
STPH150	1 1/2 hp high pressure fixed speed	37"-132"
STPM200	2 hp fixed speed with MagShell™	37"-132"
STPHM200	2 hp high pressure fixed speed with MagShell™	37"-132"

- Notes:
1. Remove "M" from model number for non-MagShell™ pump motor assembly.
 2. STP models are compatible with fuel mixtures containing up to 15% ethanol or methanol with gasoline, and 20% MTBE, 20% ETBE or 17% TAME with gasoline.
STPAG models are compatible with fuel mixtures containing up to 100% ethanol or methanol with gasoline, and 20% MTBE, 20% ETBE or 17% TAME with gasoline.
 3. All models are supplied with a standard check valve unless factory option "R" or "W" is specified.
 4. All above models require single-phase, 208-230 VAC, 60 Hz incoming power.
 5. 4" riser pipe, if supplied locally, must be 4 1/2" OD by 3/16" WT tubing.
 6. For riser pipe lengths 31" to 69", adder charge applies.
 7. STPAG models are UL listed for compatibility with fuel mixtures containing up to 85% ethanol with gasoline.

*Model length (A) defined as the dimension from turbine manifold bottom to pump motor inlet. Model length (A) can be a minimum of 37" to a maximum of 211". Adder charge applies to list if model length (A) is 133" to 180" (charge is for boards to protect STP shipment). Adder charge applies to list if model length (A) is 181" to 211" (charge is for crating STP).

Factory Installed Options

(specified in model number at time of STP order)

Designation	Description
F	Floating suction adapter, 1 1/2" NPT female, must be factory installed
K	IFS (intake filter screen), factory assembled to pump motor assembly
R	Model R check valve, factory installed, for Veeder Root PLLD Line Leak
W	Model W check valve, factory installed, for Red Jacket PPM4000 Line Leak
AG	Alcohol-gasoline compatible

Field Installed Options

(fixed speed specific accessories)

Part Number	Description
400137908	Syphon check valve, alcohol-gasoline compatible (when ordered with STP)
400818921	STP-CBS, single-phase control box with lockout switch, 110 Volt coil
402312921	STP-DHI-SCI, combo DHI with factory wired STP-SCI (when purchased with a 4" STP)
402312921	STP-DHI-SCI, combo DHI with factory wired STP-SCI (when purchased without a 4" STP)*
402313921	STP-DHI-CBS, combo DHI with factory wired STP-CBS
402459931	Model 65 psi check valve (for slave of manifolded STPs with Veeder Root PLLD)
402507930	Secondary syphon kit (when two syphon primes are required for one STP)
5800100215	STP-SCI, single-phase smart controller (when purchased without a 4" STP)
5800100215	STP-SCI, single-phase smart controller (when purchased with a 4" STP)*
5800300100	STP-DHI, dispenser hook isolation for 110 Volt dispenser handle switches, up to eight each

*When purchasing STP-SCI or STP-DHI-SCI in equal quantities of fixed speed 4" STPs, the STP-SCI or STP-DHI-SCI will be invoiced at special discount pricing.

Mechanical Line Leak Detector

For use with 4" STPs, the MLD product line is precision built, with unique construction features that provide busy stations with maximum flow rates and long service life. The MLD is offered in three models to match your exact application, ensuring accurate, nuisance-free operation critical to profitable station operation.

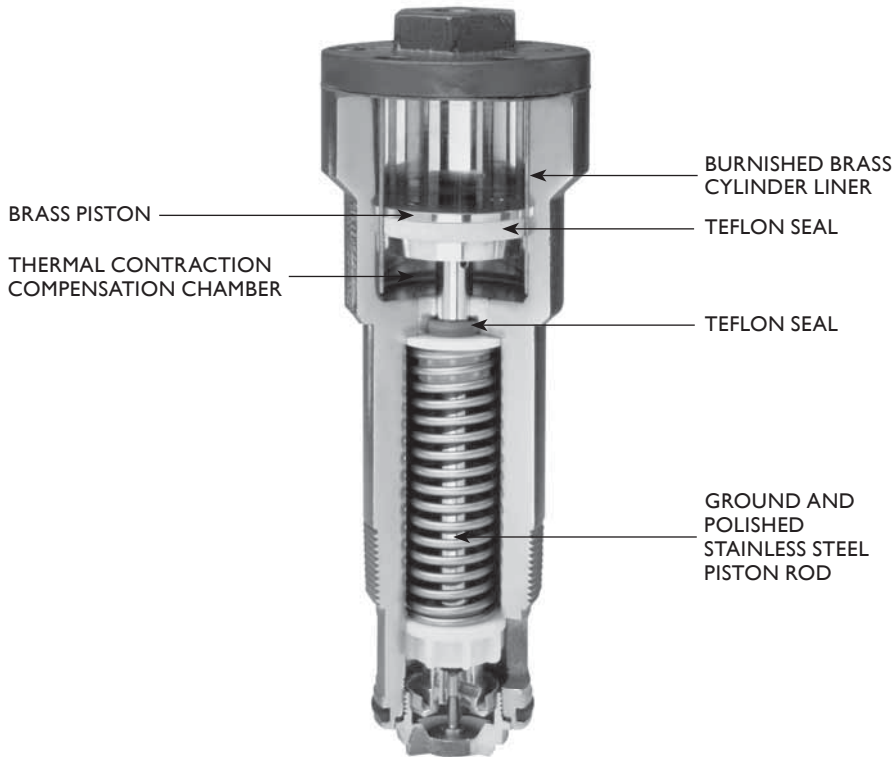

Specifications:

- Three models: STP-MLD (blue) for gasoline, STP-MLD-D (tan) for diesel and STP-MLD-E (grey) for some expandable pipe applications.
- Solid brass piston has 1-5/8" of travel to move the leak detection poppet fully out of the flow, offering minimum flow restriction and maximum flow rates.
- Burnished brass cylinder liner and polished stainless steel piston rod ensure smooth operation and long life from the Teflon seal.
- Thermal compensation chamber of 5¾ cubic inches helps minimize thermal contraction nuisance tripping.

Liquid Compatibility

- Max. liquid viscosity: 70 SSU at 60 °F (15 °C).
- STP-MLD and STP-MLD-E models are compatible with fuel mixtures containing up to 100% ethanol or methanol, and 20% MTBE, 20% ETBE or 17% TAME with gasoline, as well as diesel fuels, fuel oils, kerosene, Avgas and jet fuels.
- STP-MLD-D models are listed for diesel fuels or kerosene only.

Approvals

- Third party certified to comply with US EPA requirements 280.41 (B) and 280.44 (A) for continuous monitoring of pressurized piping.
- Consult factory for other applicable approvals.

Quality Certification

- Franklin Fueling Systems is an ISO 9001 Certified Manufacturer.

Advantages

- All models are capable of detecting line leaks equivalent to 3 gph at 10 psi when installed properly with the appropriate fuels. All models will signal detection of leaks by restricting product delivery to less than 3 gpm and taking more than 4 seconds to open.
- All models require 2 to 3 seconds to make a line test when no line leaks exist and air is purged from piping between the discharge of the MLD and the dispenser solenoid.
- All models will remain in the "open" position during product delivery to manifold, with discharge pressures as low as 1 psi. All models will reset to "tripped" when line pressure delay is below 3 psi with pump off.
- All models will detect leaks up to 10 feet above the MLD installation point.



Mechanical Line Leak Detector
(for use with 4" STPs)*

Single Pack

Part Number	Description
400500901	STP-MLD for gasoline, blue
400501901	STP-MLD-D for diesel or kerosene, tan
400502901**	STP-MLD-E for expandable piping, grey

Three Pack

Part Number	Description
400500903	STP-MLD for gasoline
400501903	STP-MLD-D for diesel or kerosene
400502903**	STP-MLD-E for expandable piping
400503903	COMBO, contains two STP-MLDs and one STP-MLD-D

Notes: 1. MLD and MLD-E models are compatible with fuel mixtures containing up to 100% ethanol or methanol with gasoline, diesel fuels, and 20% MTBE, 20% ETBE or 17% TAME with gasoline.
 2. MLD-D models are listed for compatibility with diesel fuels and kerosene applications only.
 3. All above models will only mount in the 2" NPT leak detector port of a 4" submersible turbine, including competitive models, or in a leak detector adapter tee (sold separately below).

*Designed for limited flexible piping systems with low bulk modulus, consult factory before ordering.

**Refer to STP-MLD installation manual for complete compatibility specifications.

MLD Repair Parts and Accessories

Part Number	Description
400440101	MLD vent tube
400449901	MLD hardware pack, fittings and documentation
400518001	Leak detector adapter tee

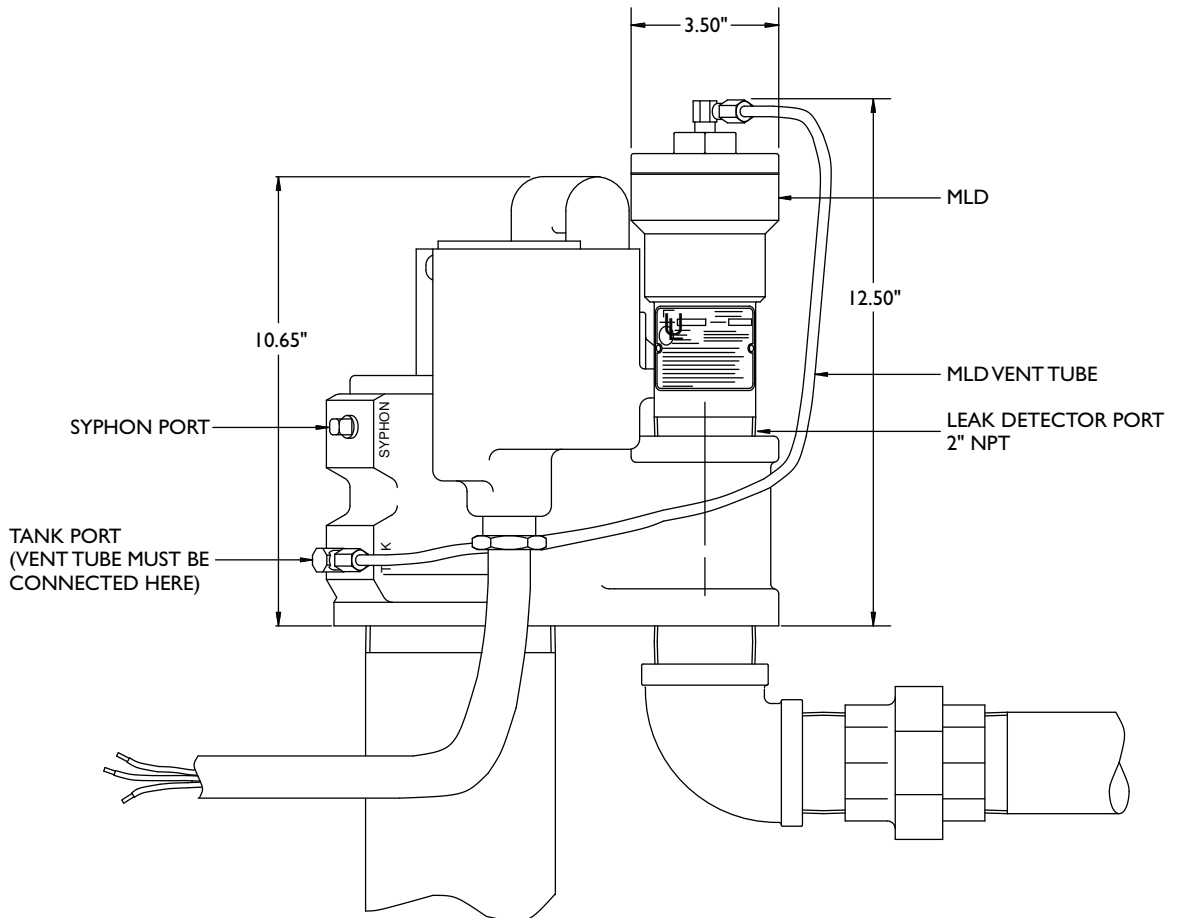

Single-Phase Smart Controller

Designed to replace standard control boxes in both new and existing installations. The STP-SCI provides valuable pump protection and performance features never before offered in one economical controller.



Feature	STP-SCI	Standard Control Box
Dry run protection with automatic reset	Yes	No
Low voltage detection	Yes	No
Pump motor failure detection	Yes	No
Open circuit detection	Yes	No
Extended pump run detection	Yes	No
Slave pump auto start operation	Yes	No
Auto sequencing of manifold pump	Yes	No
Fault diagnostic lights	Yes	No
Pump operating light	Yes	Yes
High voltage surge protection	Yes	No
Fault history storage	Yes	No
Power "ON" light	Yes	No
External run light provision	Yes	Yes
Compatible with 1/3 through 2 hp	Yes	Yes
30 Amp line relay	Yes	Yes

Specifications:

- Controller size: 8 1/2" x 5" x 3" (215 mm x 127 mm x 76 mm).
- Relay amperage rating: 30 Amps.
- Relay/hook signal voltage: 120/240 Volt.
- Compatible with all FE Petro single-phase submersibles and competitive makes.

Approvals

- Consult factory for applicable approvals.

Quality Certification

- Franklin Fueling Systems is an ISO 9001 Certified Manufacturer.

Advantages

Easy Retrofit - The STP-SCI is compatible with single-phase 1/3 through 2 hp STPs from FE Petro or other competitive models. Retrofitting an existing station requires replacing an existing control box with the STP-SCI and pressing the reset button to allow the controller to automatically "learn" the electrical characteristics of the pump.

History Storage of Pump Conditions - The STP-SCI automatically logs the last five abnormal conditions seen in the pumping system. This data is retained in non-volatile memory. Service technicians can then quickly view a history of abnormal conditions, particularly useful when troubleshooting intermittent conditions.



STP-SCI Single-Phase Smart Controller

Part Number	Description
402312921	STP-DHI-SCI, combo DHI with factory wired STP-SCI (when purchased with a 4" STP)
402312921	STP-DHI-SCI, combo DHI with factory wired STP-SCI (when purchased without a 4" STP)*
5800100215	STP-SCI, single-phase smart controller (when purchased with a 4" STP)*
5800100215	STP-SCI, single-phase smart controller (when purchased without a 4" STP)

- Notes: 1. SCI models are compatible with all single-phase FE Petro submersibles and competitive makes.
 2. One SCI required per submersible. Relay rated for 30 Amps (up to 2 hp).
 3. SCI models are not compatible for use in master/slave configurations with STP-SC models.

*When purchasing STP-SCI or STP-DHI-SCI in equal quantities of fixed speed 4" STPs, the STP-SCI or STP-DHI-SCI will be invoiced at special discount pricing.

STP-SCI Single-Phase Smart Controller Standalone Wiring Diagram

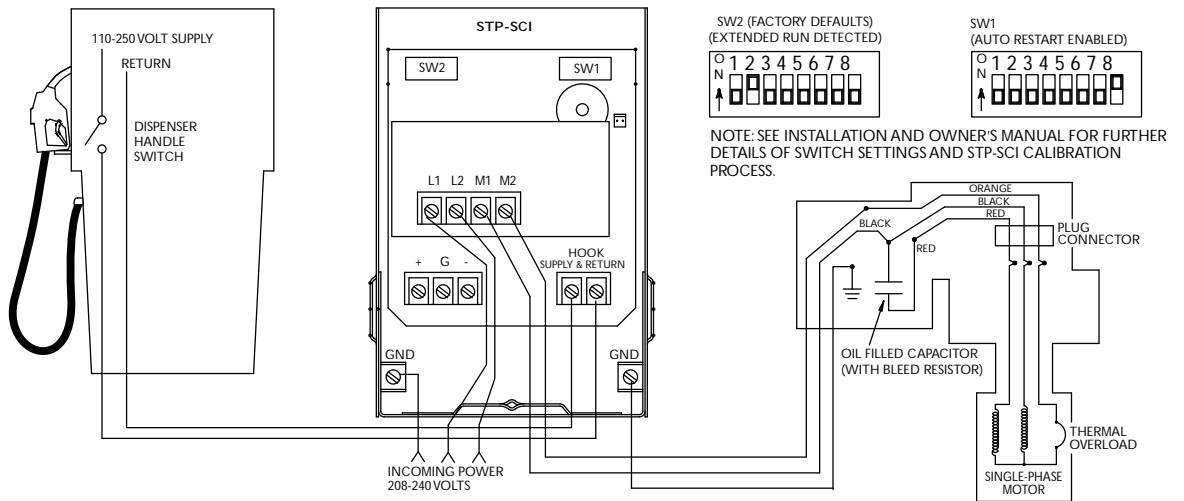

Note: See product installation instructions for further details. Wiring must conform to all federal, state and local codes. Control panels are for non-hazardous indoor use only.

Dispenser Hook Isolation

The FE Petro dispenser hook isolation device prevents electrical feedback between dispenser hook circuits as required by most electrical codes.



Conventional

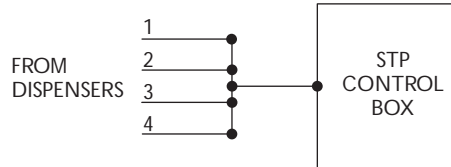

STP-DHI

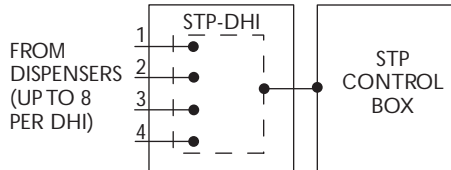

Advantages

- Optically isolates inputs from up to eight dispensers preventing damage to dispenser relay boards caused by cross-phasing.
- Prevents electrical feedback between dispenser hook circuits during periods of maintenance and service as required by NEC 514-6, 1999 and other international codes.
- Can be supplied factory-wired in tandem with the FE Petro Smart Controller or the FE Petro standard control box.
- Eliminates false STP run due to voltage leakage of multiple dispensers connected in parallel.
- Fuse-protected output to submersible pump controller.
- The STP-DHI can retrofit to any existing site.



Specifications:

- Enclosure size: 8½" x 5" x 3" (215 mm x 127 mm x 76 mm).
- Eight optically isolated inputs from dispenser.
- One STP-DHI required per product grade for up to eight dispensers.
- STP-DHI: 120V 30VA input from supply, eight 120V 10mA inputs from dispensers.
- Output fuse rating: 250V 1A, fast-acting.
- 300 Volt surge protection.
- Maximum ambient temperature rating: 120 °F.
- LEDs indicate when source power is applied and dispenser hook signals are present.
- Compatible with any submersible pump controller.

Approvals

- Consult factory for applicable approvals.

Quality Certification

- Franklin Fueling Systems is an ISO 9001 Certified Manufacturer.

STP-DHI Dispenser Hook Isolation

Part Number	Description
402312921	STP-DHI-SCI combo DHI with factory-wired STP-SCI (when purchased with a 4" STP)*
402312921	STP-DHI-SCI, combo DHI with factory-wired STP-SCI (when purchased without a 4" STP)
402313921	STP-DHI-CBS, combo DHI with factory-wired STP-CBS single-phase control box
5800300100	STP-DHI, isolates up to eight, 120 Volt dispenser handles

Notes: 1. DHI models are compatible with FE Petro submersible pump controllers and competitive pump controller makes accepting 120 Volt dispenser hook signal.
 2. DHI models can be connected together for products with more than eight dispenser handle inputs.

*When purchasing STP-DHI-SCI in equal quantities of fixed speed 4" STPs, the STP-DHI-SCI will be invoiced at special discount pricing.



STP-DHI-SCI



STP-DHI-CBS

Submersible Pumping Systems

DHI Repair Parts and Accessories

Part Number	Description
223243103	DHI fast-acting fuse, 250 VAC, 1 Amp
223885901	DHI circuit board, 120 Volt dispenser hook signal

DHI with 120 VAC Dispenser Hook Signal Wiring Diagram

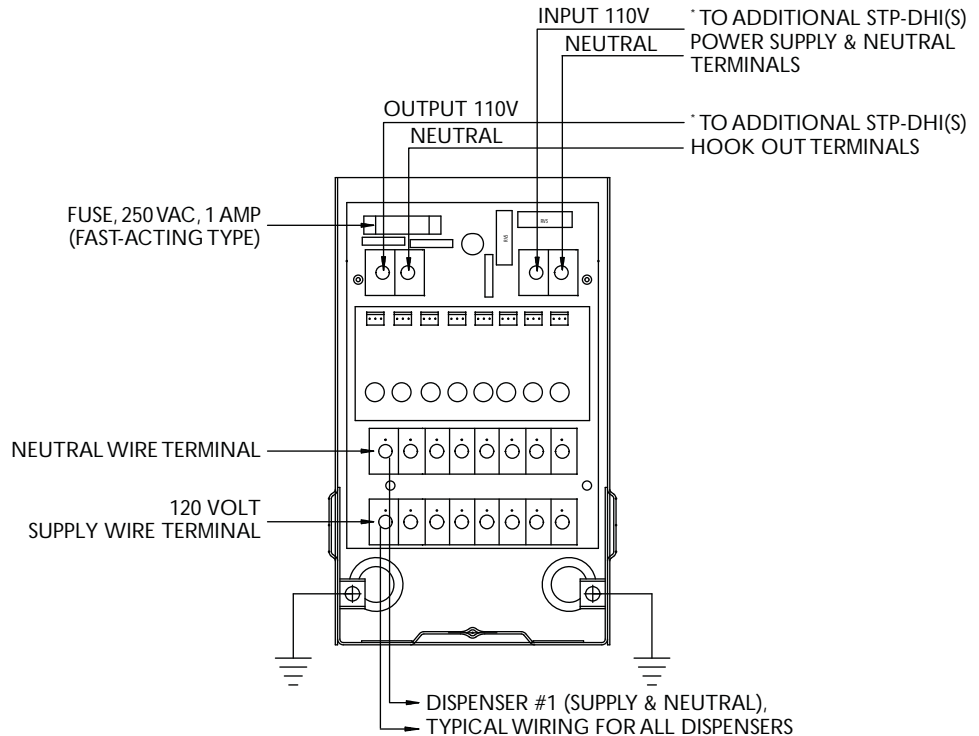

*Wiring is polarity-sensitive when multiple units are connected together.

Single-Phase Control Box

The FE Petro standard single-phase control box latches line power to the submersible when the relay is energized by a dispenser signal. Compatible with FE Petro and competitive makes of single-phase, fixed speed submersible turbines up to 2 hp.



Part Number	Description
400818921	STP-CBS, single-phase control box, with switch and lockout, 120 Volt coil
402313921	STP-DHI-CBS, combo dispenser hook isolation with factory wired STP-CBS

- Notes:
1. CBS models are compatible for use on all single-phase FE Petro submersibles and competitive makes.
 2. One CBS required per submersible, relay rated for 30 Amps up to 2 hp.
 3. Incorporates pump "ON" indicator light.
 4. Relay rated for 220 Volt pumps up to 2 hp, 30 Amps.

Advantages

- Incorporates an "ON/OFF" lockout switch.
- Relay energized with 110 Volt dispenser/hook signal.
- Franklin Fueling Systems is an ISO 9001 certified manufacturer.
- Consult factory for applicable approvals.



STP-CBS Repair Parts and Accessories

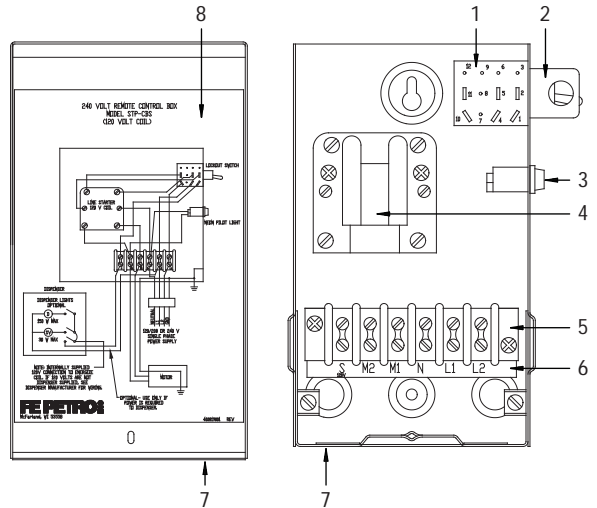

Item	Part Number	Description
1	400575001	Power switch for CBS and CBBS models
2	400574001	Power switch bracket
3	400158901	Light assembly, 120 Volt
4	400215931	Relay, 30A, 120 Volt coil
5	400278005	Six position terminal strip
6	402410001	CBS terminal strip label
7	400817901	Cover and enclosure
8	400819001	CBS wiring diagram

Submersible Pumping Systems

Intake Filter Screen



Part Number	Description
400660901	Intake filter screen single pack
400660912	Intake filter screen 12 pack carton

Model 65 PSI Relief Check Valve

For use in slave(s) STP in manifolded multiple pump installations using Veeder Root Line Leak Detection. Not available factory installed.

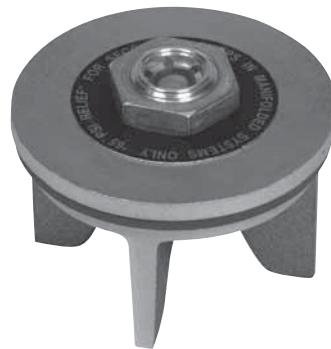

Part Number	Description
402459931	Model 65 psi relief check valve

Secondary Syphon Kit

For use when two syphon primers are required for one STP. One to syphon for condensate pod, one for syphoning two or more tanks of like product.

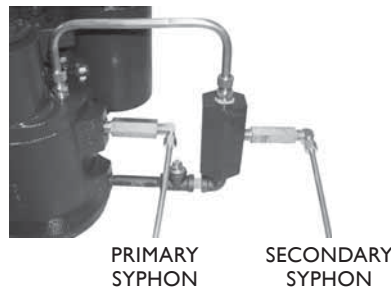

Part Number	Description
402507930	Secondary syphon kit

Replacement Pump Motor Assemblies*

Model	Description
PMA33	1/3 hp 16" pump motor assembly
PMA75	3/4 hp 18 1/4" pump motor assembly
PMA150	1 1/2 hp 21" pump motor assembly
PMAH150	1 1/2 hp 21 3/4" high pressure pump motor assembly
PMA200	2 hp 23 3/4" pump motor assembly
PMAM200	2 hp 23 3/4" pump motor assembly with MagShell™
PMAH200	2 hp 24 1/2" high pressure pump motor assembly
PMAHM200	2 hp 24 1/2" high pressure pump motor assembly with MagShell™

Note: Remove "M" from model number for non-MagShell™ pump motor assemblies.

*For pump motor assemblies (PMAs) with floating section adapters (1 1/2" NPT female connections), specify "F" in the number; adder charge applies when ordering PMA.

Replacement Alcohol-Gasoline (AG) Pump Motor Assemblies*

Model	Description
PMAAG33	1/3 hp 16" AG pump motor assembly
PMAAG75	3/4 hp 18 1/4" AG pump motor assembly
PMAAG150	1 1/2 hp 21" AG pump motor assembly
PMAAGH150	1 1/2 hp 21 3/4" AG high pressure pump motor assembly
PMAAG200	2 hp 23 3/4" AG pump motor assembly
PMAAGM200	2 hp 23 3/4" AG high pressure pump motor assembly with MagShell™
PMAAGH200	2 hp 24 1/2" AG high pressure pump motor assembly
PMAAGHM200	2 hp 24 1/2" AG high pressure pump motor assembly with MagShell™

Note: Remove "M" from model number for non-MagShell™ pump motor assemblies.

*For pump motor assemblies (PMAs) with floating section adapters (1 1/2" NPT female connections), specify "F" in the number; adder charge applies when ordering PMA.

Replacement Variable Speed Pump Motor Assemblies*

Model	Description
PMAMVS2	2 hp 20" variable speed pump motor assembly with MagShell™
PMAAGMVS2	2 hp 20" AG variable speed pump motor assembly with MagShell™
PMAMVS4	4 hp 25" variable speed pump motor assembly with MagShell™
PMAAGMVS4	4 hp 25" variable speed pump motor assembly with MagShell™

Note: Remove "M" from model number for non-MagShell™ pump motor assemblies.

*For pump motor assemblies (PMAs) with floating section adapters (1 1/2" NPT female connections), specify "F" in the number; adder charge applies when ordering PMA.

4" STP Extractable Sections (less manifold, riser and PMA)

Model	Description
STPEXT-XXX-XX	Fixed length extractable
STPEXT-VL1-XX	Variable length #1 extractable
STPEXT-VL2-XX	Variable length #2 extractable
STPEXT-VL3-XX	Variable length #3 extractable
STPAGEXT-VL1-XX	AG variable length #1 extractable
STPAGEXT-VL2-XX	AG variable length #2 extractable
STPAGEXT-VL3-XX	AG variable length #3 extractable



Smart Controller
(STP-SC and STP-SCI)

Item	Part Number	Description
1	223835931	SC upper board cover
2	223840930	SC lower relay board, limited availability
Not Shown	225000930	SCI lower board control
Not Shown	225005930	SCI upper board relay

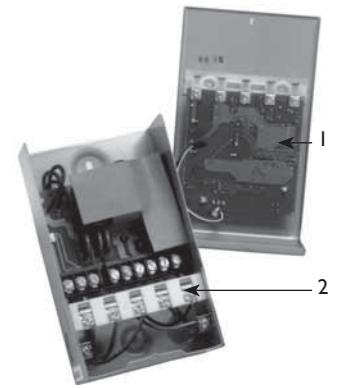

STP-DHI Dispenser Hook Isolation Box

Item	Part Number	Description
1	223243103	250 AC fast-acting fuse
2	223885901	120 Volt circuit board (includes fuse)

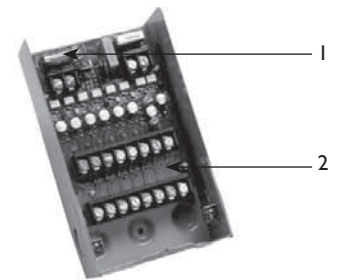

MagVFC™ and IST-VFC

Part Number	Description
223919930	MagVFC™ fan assembly
225040930	MagVFC™ user interface board
228289930	MagVFC™ normally open relay
400992930	IST-VFC harness, limited availability
402500930	IST-VFC software upgrade kit, rev. 1.5
402623930	MagVFC™ window lens
402811930	Re-certified IST-VFC, limited availability



MagVFC™

PMA, Riser and Check Valve for Variable Length and Fixed Length Pumps

Item	Part Number	Description	Qty
1	400125001	3/16" × 1-5/8" spiral pin	1
2	400615001	Manual relief plug	1
3	400211114	O-ring, plug	1
4	400627001	Retaining ring	1
5	400616001	Manual relief screw	1
6	400333012	Relief screw, top O-ring	1
7	400333007	Relief screw, bottom O-ring	1
8	400628901	Manual relief plug assembly, includes items #2 and #3	1
9	400629901	Manual relief screw assembly, includes items #4, #5, #6 and #7	1
10	400259001	1/4" NPT pipe plug, may be purchased locally	3
11	400137937	Syphon check valve	-
12	400221930	Discharge manifold, includes #1, #8, #9 and two #10	1
13	151213930 151213932	156" lead assembly 240" lead assembly	1
14	Purchase locally	Stationary vapor tube, 3/8 OD × 7/20 WT	-
15	4001689XX (XX = length)	Riser, 4-1/2" OD × 3/16" WT steel tubing 7"-19" 20"-30" 31"-49" 50"-69"	1
16	Purchase locally	1/2" steel banding	-
17	400600002	5/16-24 × 7/16" set screw for variable lengths only	3
	400600001	5/16-24 × 7/16" set screw for old two-piece variable lengths	1
18	400333015	Lead assembly O-ring	4
19	400264009	5/16-18 × 1-1/8" socket head cap screw, may be purchased locally	4
20	400263004	5/16" high-collar lock washer, may be purchased locally	1
21	402449001	AG compatible PMA gasket	1
22	PMA XXX	Pump motor assembly, includes item #34 (XXX indicates options and horsepower)	2
23	400981001	3/8-16 × 1" Hex head screw	2
24	400285002	3/8" standard lock washer, may be purchased locally	1
25	400197930	Manifold assembly cover, includes #10, #26, two #23 and two #24	1
26	400333238	AG compatible O-ring	1
27	400147930	Clamp valve assembly	1
28	400174930	Check valve spring	1
32	#29 - 400988931	Standard check valve, includes item #26	1
	#30 - 400988932	Model R check valve, includes item #26	1
	#31 - 400988933	Model W check valve, includes item #26	1
33	152350902	PMA hardware pack, includes #21, and four #19 and #20	-
Not shown	400216905	AG compatible O-ring kit, includes items #3, #6, #7 and #26 on this page and items #2, #10, #13, #17, #20 and #21 on page 35	-

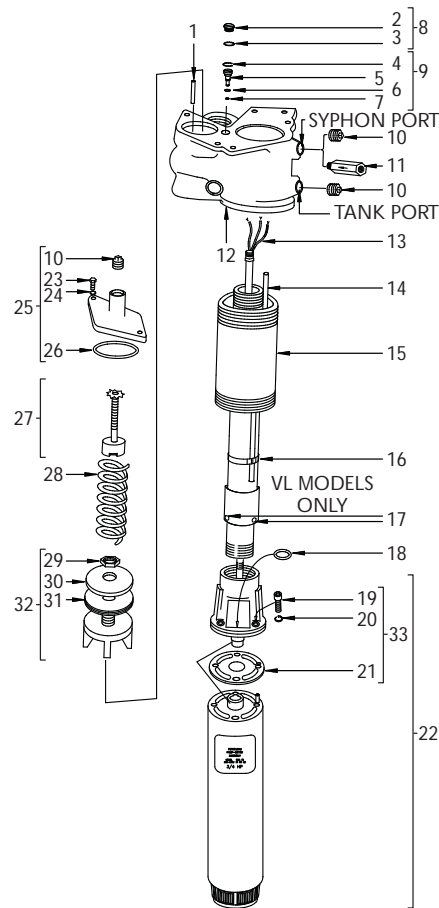

Discharge Manifold Assembly

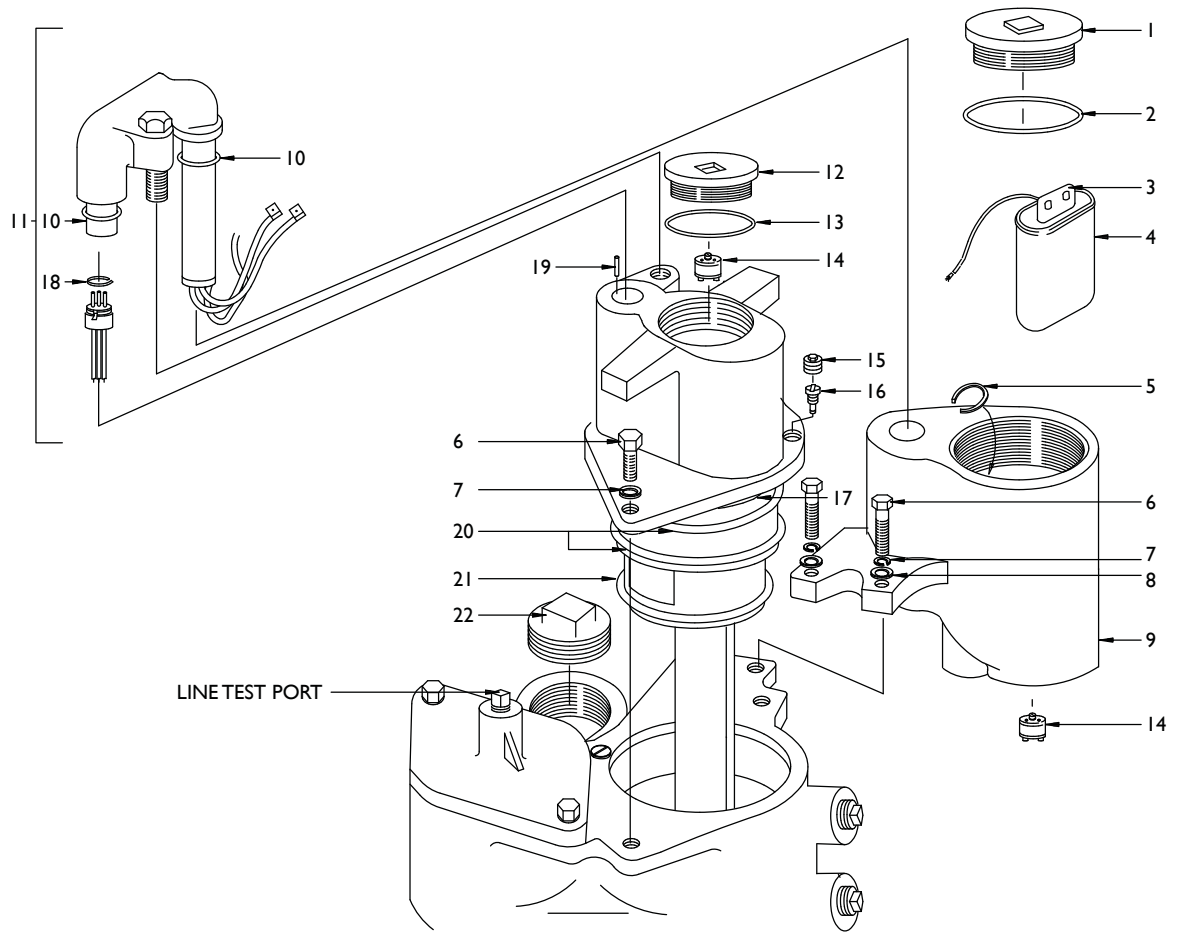

Item	Part Number	Description	Qty.
1	400192930	Junction box cover, includes item #2	1
2	400210233	O-ring	1
3	400655001	Capacitor boot	1
4	400170931	Capacitor assembly for 1/3 to 1 1/2 hp, 60 Hz, 15µfd, 380 Volt single-phase; includes one black lead	1
	400170934	Capacitor assembly for 2 hp, fixed speed, 60 Hz, 40µfd, 370 Volt single-phase; includes one black lead	
5	400257001	Retaining ring	1
6	400258002	3/8-16 × 1-1/4 Hex head bolt, may be purchased locally	4
7	400285002	3/8 standard lock washer, may be purchased locally	4
8	400280001	3/8 standard flat washer, may be purchased locally	2
9	400651930	Junction box assembly, includes two #6, #7 and #8	1

Item	Part Number	Description	Qty.
10	400210212	O-ring	2
11	400200930	Wire connector kit, includes male/female connectors, two #10, one #5, and #18	1
12	400589930	Cover, includes item #13	1
13	400210229	O-ring	1
14	400236903	Contractor's plug	2
15	400259002	3/8" NPT pipe plug, may be purchased locally	2
16	400562901	Syphon jet assembly	1
17	400211046	O-ring	1
18	400249001	Retaining ring	1
19	400250002	1/8" dia. × 1/2" roll pin	1
20	400333343	AG compatible O-ring	2
21	400333340	AG compatible O-ring	1
22	400259005	2" NPT square head plug	1

High Capacity Submersible Turbine Pumps

Available with either 3 or 5 hp, the FE Petro high capacity pump delivers efficient, reliable and quiet performance when high volumes or high speed deliveries of gasoline or diesel fuel are required.



Advantages

High Performance - FE Petro's two-stage centrifugal pump is coupled with a dependable Franklin Electric motor to provide higher heads, faster fuel delivery and lower cost operation. Motors are all three-phase for smooth operation and are available in various voltages. Units come standard with a 6" diameter riser pipe to mount the pump to the tank.

Ease of Maintenance - If service is required, FE Petro products are designed to put the operator back in business fast. Maintenance on the pump motor assembly can be performed without having an electrician on site. Large diameter pins and sockets provide automatic open circuits and disconnecting of the wiring when the extractable portion of the pump is removed. Properly spaced lifting eyes facilitate the removal of the unit without disturbing the discharge piping. The pump motor assembly is easily removed from the discharge head by removing four bolts and using standard pusher bolts. Replacement pump motor assemblies are available for comparably sized competitive pumps.

Reliability - Quality engineering and simplicity of design work to ensure years of reliable performance from every high capacity unit. The continuous duty, three-phase Franklin Electric motor with carbon bearings and stainless steel journals is FE Petro's standard. The impellers, made of molded Delrin, and diffusers of hard coated aluminum, with a stainless steel pump shaft, assure trouble-free operation in motor fuels. Dual (180° opposed) 3" horizontal discharge ports provide easy installation, and two built-in line check valves reduce installation costs. Two line pressure relief valves protect the dispensers, meters and piping from abnormal pressures due to thermal expansion. The mesh screen on the pump inlet prevents large particles from entering the unit and the unit is compatible with existing high capacity leak detector technology. New units are easily connected to field wiring without disassembly.

Satisfaction - Each and every high capacity pump is built to your tank and bury specifications and the complete assembly is performance tested to ensure that your needs are met. All high capacity pumps are UL listed and meet the requirements of UL 79.

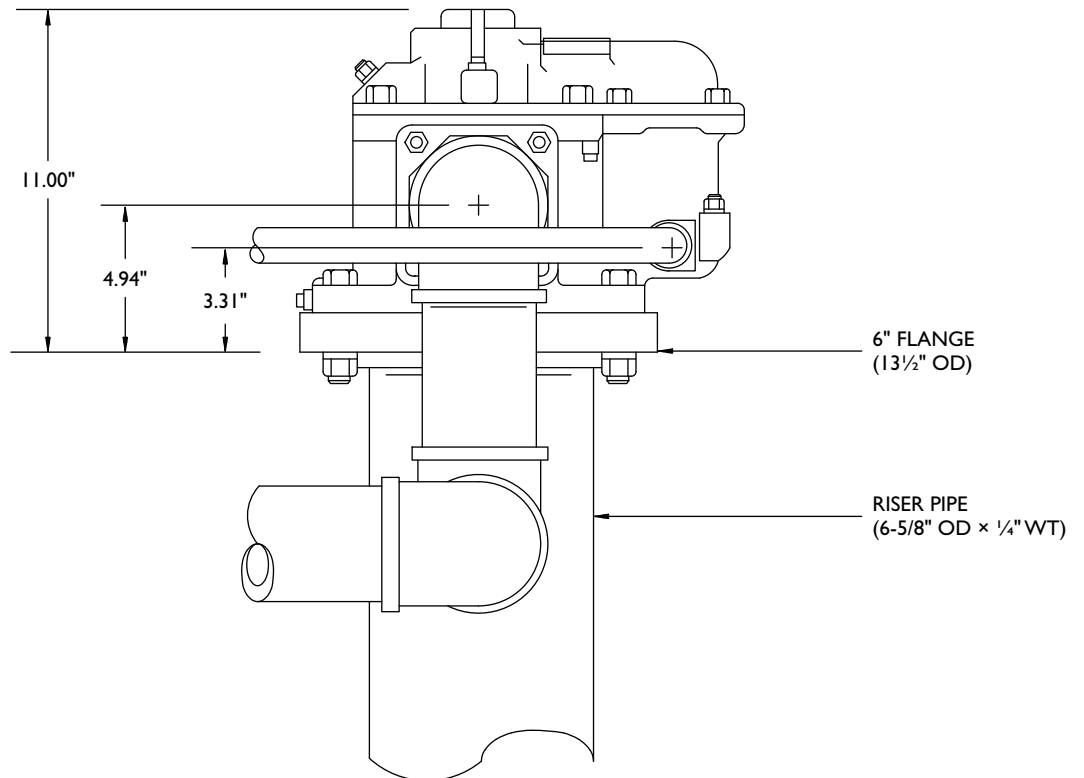
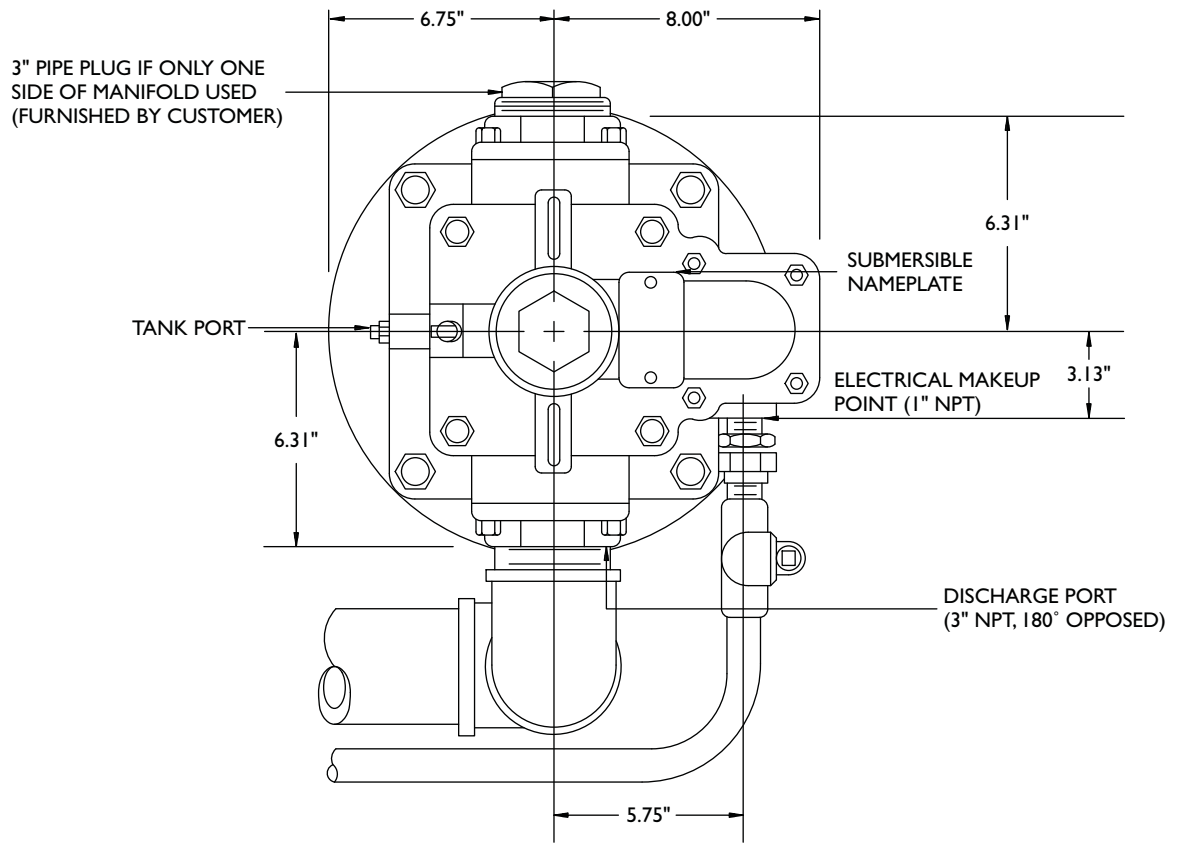

High Capacity Pump Ordering Guide

Submersible Pumping Systems

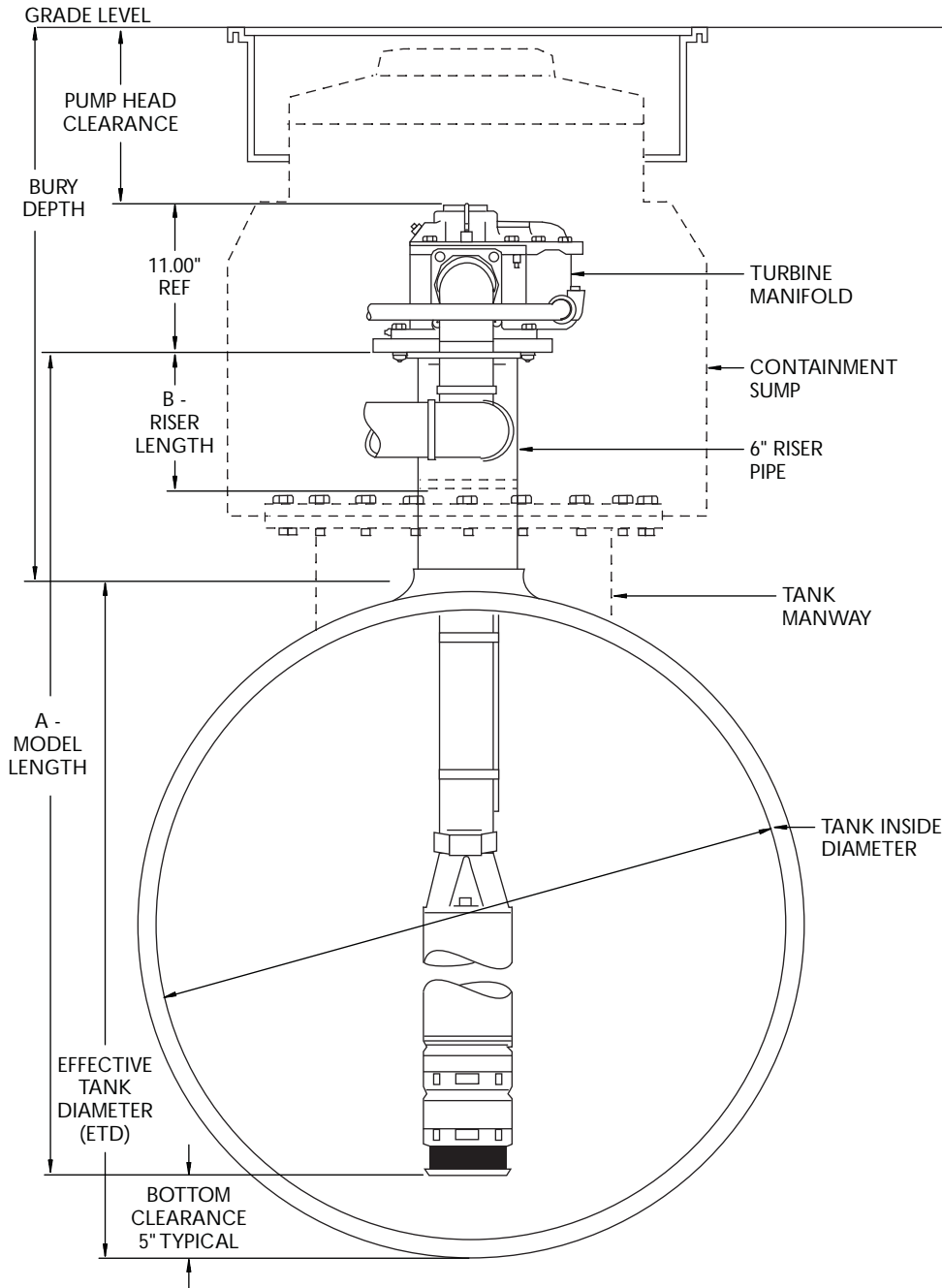

- Note: 1. Effective tank diameter (ETD) = Inside tank diameter (to top of 4" bung), including tank manway and/or sump adapter.
 2. Model length (A) = ETD plus riser length minus bottom clearance minus 1" thread engagement.
 3. Riser length (B) = Bury depth (to top of tank) minus pump head clearance minus tank manway and/or minus sump adapter.



High Capacity Submersible Turbine Pump Model Designation System

A typical turbine model designation has up to five components to define the pump being supplied as follows:

STP XXXXX Y - A - B

STP = Basic Model Designation

XXXXX = Factory Installed Options

HCP model designations may include one or more of the following characters in alphabetical order:

AG = Alcohol-gasoline compatible (100% ethanol or methanol capable)
 Note: Standard models 0% to 15% ethanol or methanol capable

F = Floating suction adapter (3" NPT male adapter)

***R** = Model R check valve (24 psi relief/22 psi reset for PLLD)

***Note:** If not otherwise specified, all HCP models supplied with standard model check valve (40 psi relief/35 psi reset for MLD and TS-LS300).

Y = Pump Motor Horsepower/ Electrical Rating

3 = 3 hp fixed speed, 208-230 VAC

5 = 5 hp fixed speed, 208-230 VAC

5H = 5 hp fixed speed, 460 VAC

5G = 5 hp fixed speed, 575 VAC

A = Model Length

Model length is expressed as three numeric characters that indicate the length of the HCP from the turbine manifold bottom to the pump motor inlet in inches, available from 60" to 200" (additional charge for models 132" and longer).

B = Riser Pipe Length

Riser pipe length is expressed as two numeric characters that indicate the total length of the riser in inches. Riser pipes are available from 6" to 60" in three inch increments (additional charge and lead time for risers 33" or longer).

High Capacity Submersible Turbine Pump Specifications

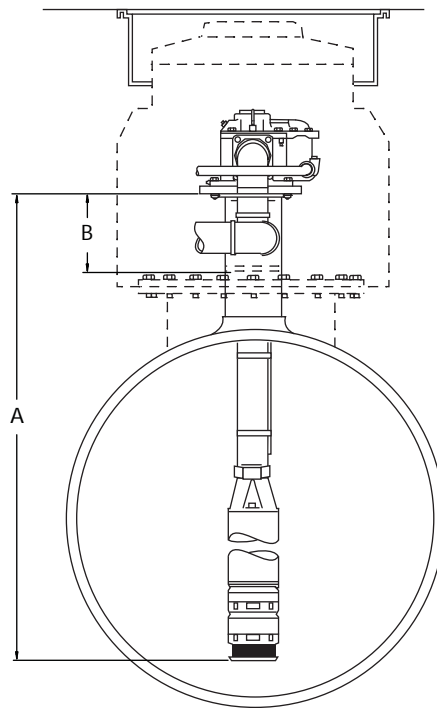

For full diagram see page 38.

Power Requirements

- High capacity pump models require three-phase, 60 Hz incoming power.
- High capacity pump models are available as 208-230 VAC, 460 VAC or 575 VAC versions.
- High capacity pump models are available in 3 hp and 5 hp versions.
- STP-SCIII three-phase smart controllers and STP-CB3/5 three-phase control boxes are available for high capacity pump control.

Pump Motor

- Fixed speed, 3450 rpm, multi-stage centrifugal type pump motor with built-in, automatic, thermal overload protection.
- High capacity pump 60 Hz models are available as two-stage versions only.

Liquid Compatibility

- Max. liquid viscosity: 70 SSU at 60 °F (15 °C).
- Standard models are UL and cUL listed for fuel mixtures containing up to 15% ethanol or methanol, and 20% MTBE, 20% ETBE or 17% TAME with gasoline.
- STPAG models are compatible with fuel mixtures containing up to 100% ethanol or methanol, and 20% MTBE, 20% ETBE or 17% TAME with gasoline.
- HCP models can also be used with diesel fuels, fuel oils, kerosene, Avgas and jet fuels in a non-gelled pourable state.
- All wetted elastomers are made of a high grade, fluorocarbon Viton® compound.

Standard Features

- Pressure relief valve: cartridge design available in two pressure relief settings, external to check valve. Standard model relieves at 40 psi and resets above 35 psi.
- Syphon: external venturi-type syphon primer supplied as submersible accessory.
- Air eliminator: every submersible includes tank return path to provide active air elimination.

Approvals

- Consult factory for applicable approvals.

Quality Certification

- Franklin Fueling Systems is an ISO 9001 Certified Manufacturer.
- Viton® is a registered trademark of DuPont Dow Elastomers.



3 hp Fixed Speed High Capacity Performance Chart

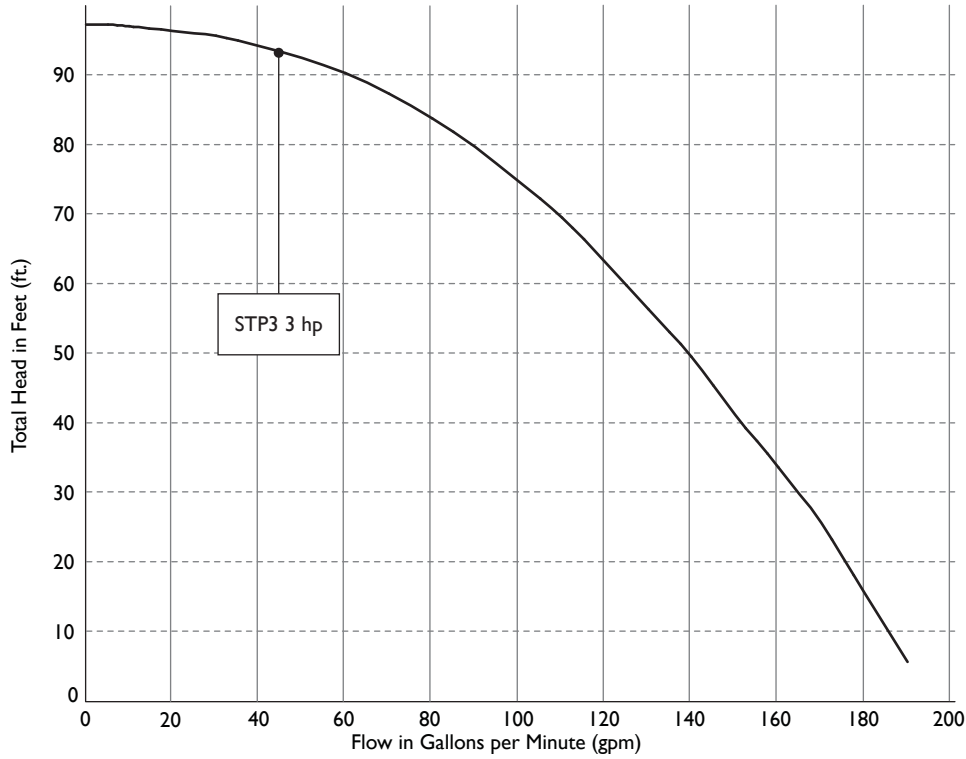

Note: Performance based on pumping solvent (0.78 specific gravity). Pressure is taken at the manifold discharge outlet. STP3 models are powered by a three-phase, 60 Hz, 208/230 Volt power supply.

5 hp Fixed Speed High Capacity Performance Chart

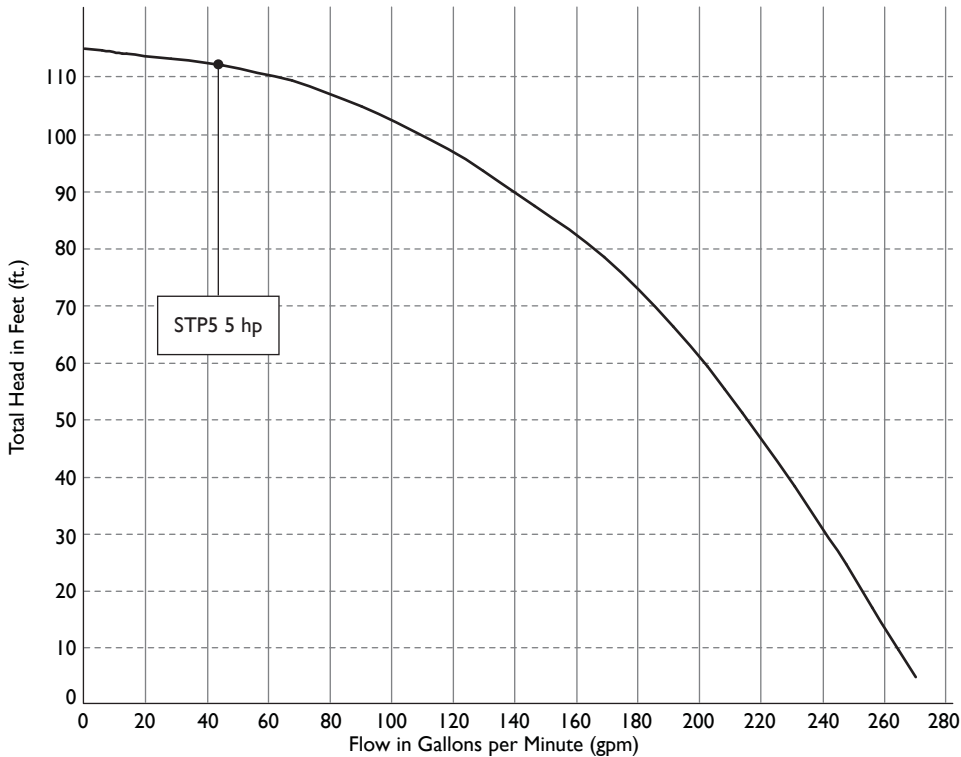

Note: Performance based on pumping solvent (0.78 specific gravity). Pressure is taken at the manifold discharge outlet. STP5 models are powered by a three-phase, 60 Hz, 208/230 Volt power supply.



High Capacity Turbine Pumps

Model	Description
STP3	3 hp 6" STP, three-phase 208-230 VAC
STP5	5 hp 6" STP, three-phase 208-230 VAC
STP5H*	5 hp 6" STP, three-phase 460 VAC
STP5G*	5 hp 6" STP, three-phase 575 VAC

Note: For riser pipe lengths 33" to 60", adder charge applies.

*Please call customer service for lead time on this item.

Alcohol-Gasoline Units

Model	Description
STPAG3	3 hp AG 6" STP, 208-230 VAC
STPAG5	5 hp AG 6" STP, 208-230 VAC
STPAG5H*	5 hp AG 6" STP, 460 VAC
STPAG5G*	5 hp AG 6" STP, 575 VAC

Note: For riser pipe lengths 33" to 60", adder charge applies.

*Please call customer service for lead time on this item.

Length Adder

Part Number	Description
401190911	Additional charge for pump lengths (A) from 132" to 170"
401190914	Additional charge for pump lengths (A) from 171" to 200"

Note: Model length (A) is defined on page 38. Model length (A) can be a minimum of 60" to a maximum of 200".

Factory Installed Options

Designation	Description
401165905	Syphon system (when purchased with STP)
401227001	Floating suction adapter, 3" male NPT (must be ordered with STP)
R	Model R relief valve factory installed, for Veeder Root PLLD

Field Installed Options

Model	Description
STP-CB3	3 hp, 208-230 VAC, 60 Hz, three-phase motor starter, 120 VAC coil
STP-CB5	5 hp, 208-230 VAC, 60 Hz, three-phase motor starter, 120 VAC coil
STP-CB5G	5 hp, 575 VAC, 60 Hz, three-phase motor starter, 120 VAC coil
STP-CBB5H	5 hp, 460 VAC, 60 Hz, three-phase motor starter, 220 VAC coil
STP-SCIII	Three-phase smart controller, 120 VAC coil (when ordered with a 6" high capacity STP)*
STP-SCIII	Three-phase smart controller, 120 VAC coil (when ordered without a 6" high capacity STP)

Note: Three-phase smart controller is compatible with FE Petro 208/230 Volt 3 and 5 hp high capacity STPs and like competitive makes. Not available for 460 or 575 Volt models.

*When purchasing STP-SCIII in equal quantities of fixed speed 6" STPs, the STP-SCIII will be invoiced at special discount pricing.

6" STP Extractable (less manifold, riser and PMA)

Model	Description
HCPEXT-XXX-XX	6" fixed length extractable
HCPAGEXT-XXX-XX	AG compatible 6" fixed length extractable

High Capacity Line Leak Detector

The High Capacity MLD product line is based on our standard STP-MLD unit design. The High Capacity MLD's compact design allows installation in the same containment sump as the submersible pump, greatly reducing the amount of unprotected leak points between the submersible and the MLD.

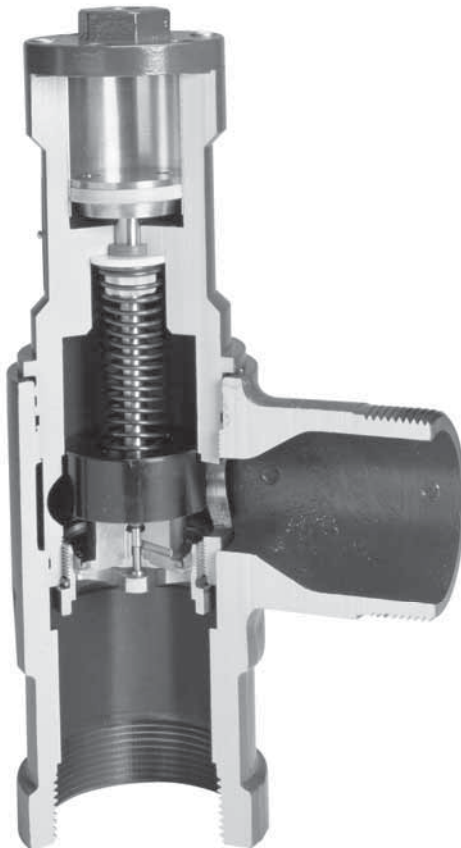

Specifications:

- Detects leaks of 3 gph (11.4 lgp) or greater at 10 psi (69 kpa).
- Third party evaluated to comply with US EPA requirements 280.41 (B) and 280.44 (A) for continuous monitoring of pressurized piping systems with maximum of 396.60 gallons for rigid pipelines, maximum of 95.50 gallons for flexible pipelines, maximum of 492.10 gallons for combination of rigid and flexible pipelines.
- Size: 7¾" × 15" (197 mm × 381 mm).
- Weight: 28 pounds (12.7 kg).
- The MLD-HC will remain in the open flow position with dynamic line pressure at 2 psi (13.8 kpa) at the outlet.
- Maximum static head pressure without affecting operation is 12' (3.7 m) from MLD-HC to dispensing point.
- Minimum height required from 3" (76.2 mm) NPT port centerline for top clearance is 9½" (241 mm). Not position sensitive. Can be installed horizontally to reduce clearance to 3" (76.2 mm).
- Compatible with all blends of motor fuels including alcohol blends from 0 to 100% ethanol or methanol, 20% MTBE or ETBE with 80% gasoline, or 17% TAME with 83% gasoline as well as diesel, fuel oil, Avgas, jet fuel or kerosene.
- Two models available: STP-MLD-HC for gasoline, STP-MLD-HCD for diesel.

Approvals

- Consult factory for applicable approvals.

Quality Certification

- Franklin Fueling Systems is an ISO 9001 Certified Manufacturer.

Advantages

Low Line Restriction - Piston design offers the maximum flow rate possible by keeping flow restriction through the leak detector at an absolute minimum. Piston has a full 1-7/8" (47.6 mm) of travel to move the leak detector poppet fully out of the flow path when product is being pumped.

Faster Installation - MLD-HC can be installed after purging air on new installations.

Piston Design - Piston cylinder has 5¾ cubic inches (94.22 cc) of volume to help minimize nuisance tripping due to thermal contraction during cold weather.

MLD-HC Seal - Threads seal using O-rings instead of thread sealant. This seal design makes for simple installation and removal of MLD-HC without large wrenches in the tight working environment of the containment sump.



High Capacity Mechanical Leak Detectors*

Model	Description
401315902	STP-MLD-HC leak detector complete with adapter, for gasoline
401320902	STP-MLD-HCD leak detector complete with adapter, for diesel
401315901	Replacement high capacity leak detector for gasoline only
401320901	Replacement high capacity leak detector for diesel only
401316930	Replacement cover assembly
401325901	Replacement "T" housing and cover assembly
400449902	MLD-HC hardware pack, includes fittings and documentation

*Refer to high capacity MLD installation manual for complete fuel compatibility specifications.

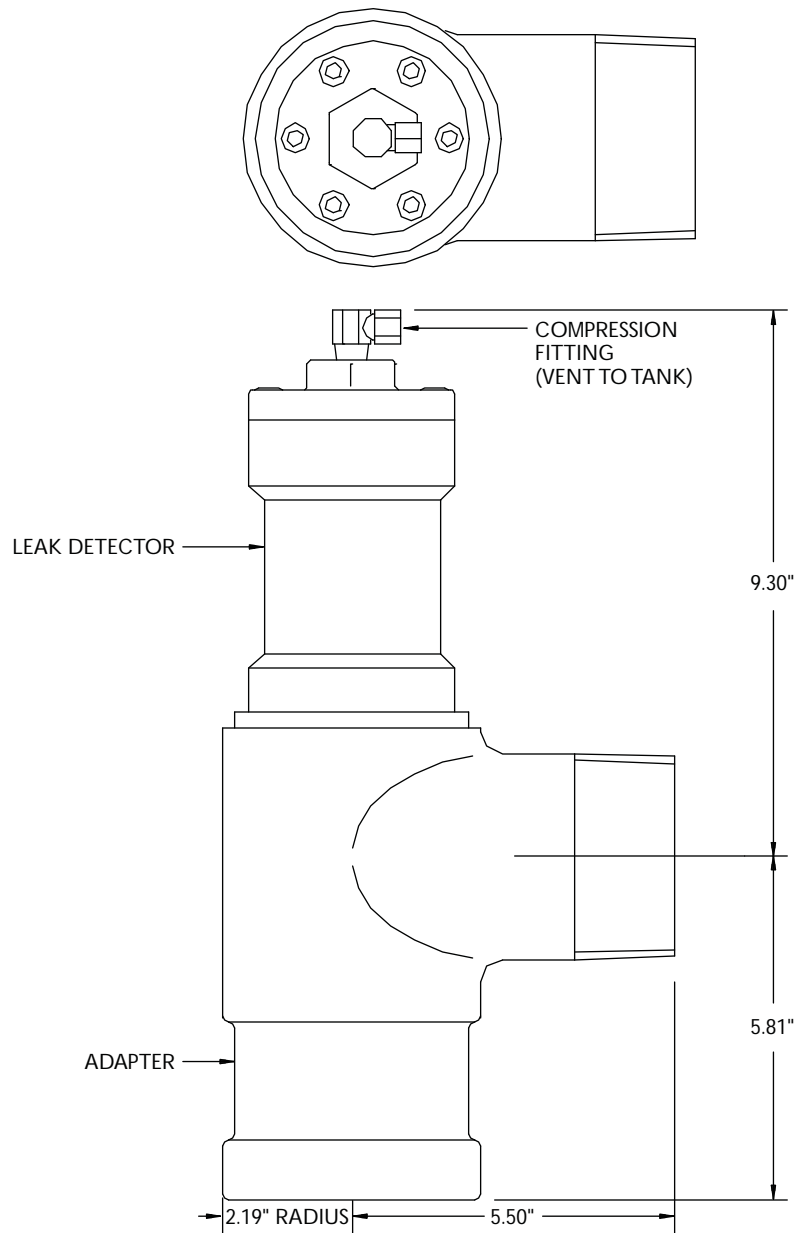

Three-Phase Smart Controller

STP-SCIII is designed to replace three-phase motor starters in both new and existing locations. The STP-SCIII controller provides valuable pump protection and performance features for an economical price.



Specifications:

- Enclosure size: 9-1/16" x 7-6/8" x 5 1/2" (230 mm x 196 mm x 140 mm).
- Compatible with three-phase FE Petro 3 and 5 hp submersibles and most competitive makes.
- Relay rating: 5 hp.
- Relay coil Amp consumption when pump is operating: 80 mA.
- Relay coil (hook) signal rating: 120 VAC.
- Pump "ON" indication is provided by flashing green light.
- Power "ON" indication is provided by steady green light.
- Flashing red light indicates fault condition. Number of flashes indicates specific fault.
- Audible alarm alerts operator of fault.
- Built-in voltage surge protection.
- Flashing yellow light indicates RS 485 is communicating.
- RS 485 com port.

Approvals

- Consult factory for applicable approvals.

Quality Certification

- Franklin Fueling Systems is an ISO 9001 Certified Manufacturer.

Advantages

Easy Retrofit - The STP-SCIII is compatible with most existing three-phase submersibles from 3 to 5 hp. Retrofitting existing stations is as simple as replacing the existing three-phase motor with the STP-SCIII. No additional wiring is required.

Continuous Diagnostics - The STP-SCIII constantly monitors for abnormal conditions that reduce motor life or cause down-time. When any of these conditions exists, the STP-SCIII will alert the service technician to the source of the problem: dry run, extended run, overvoltage, undervoltage, relay fault, voltage/current unbalance, locked rotor, phase loss or open circuit.

Pump Auto-Start - Provides "on demand" automatic pump start of up to eight submersible pumps manifolded to the same discharge line. Lead pump starts to satisfy initial demand and additional pumps are started as demand increases, reducing power consumption and extending pump life.



STP-SCIII Three-Phase Smart Controller*

Part Number	Description
5800103200	STP-SCIII three-phase smart controller (when purchased with a 6" STP)
5800103200	STP-SCIII three-phase smart controller (when purchased without a 6" STP)

Notes: 1. One STP-SCIII required per submersible, relay rated for 30 Amps.

2. STP-SCIII models do not utilize the pump motor thermal overload wiring (blue leads).

*STP-SCIII is compatible with FE Petro 3 and 5 hp submersibles and competitive makes except the 460 and 575 Volt models. When purchasing STP-SCIII in equal quantities of fixed speed 6" STPs, the STP-SCIII will be invoiced at special discount pricing.

STP-SCIII Repair Parts

Item	Part Number	Description
1	223878101	Three-phase relay, 120 Volt coil
2	223905901	Logic board assembly
3	223910901	208-230 Volt power board assembly

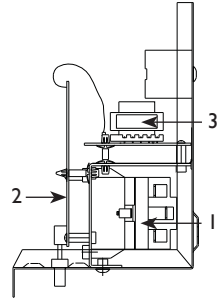

STP-SCIII Three-Phase Smart Controller Standalone Wiring Diagram

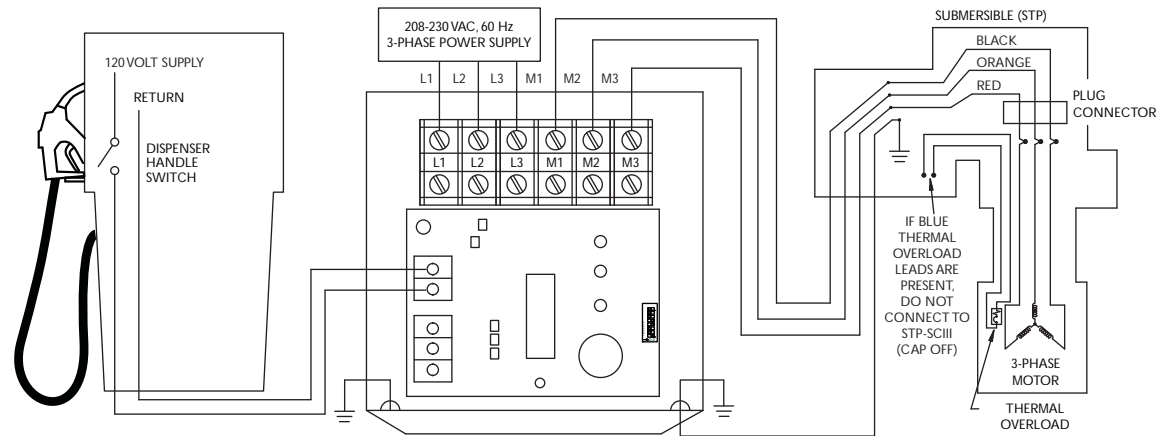

Note: See product installation instructions for further details. Wiring must conform to all federal, state and local electrical codes. Motor control panel is for non-hazardous location use only.

STP-CB 3/5 Magnetic Starter

The FE Petro magnetic starter incorporates ambient compensated relays with quick trip heaters and three leg protection to assure proper pump motor protection.

Submersible Pumping Systems



STP-CB 3/5 Wiring Diagram

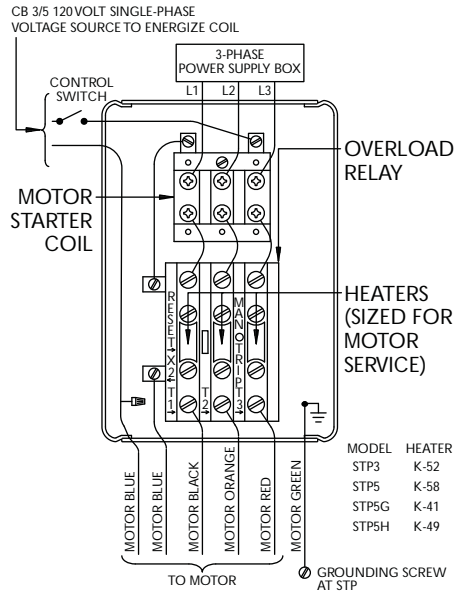

Specifications:

- Compatible with three-phase FE Petro 3 and 5 hp submersibles and most compatible models.
- Relay rating: 5 hp.
- Relay coil Amp consumption when pump is operating: 80 Amps.
- Relay coil hook signal rating: 120 Volts for all versions except CBB5H, which is energized by 220 Volt dispenser signal.
- Incorporates ambient compensation quick-trip, three-leg protection circuitry with test and reset button.

Approvals

- Consult factory for applicable approvals.

Quality Certification

- Franklin Fueling Systems is an ISO 9001 Certified Manufacturer.



CB 3/5 Repair Parts

Part Number	Description
401220901	STP-CB3 three-phase control box, 120 Volt relay, 3 hp, 208-230 Volt, 60 Hz pump control
401220902	STP-CB5 three-phase control box, 120 Volt relay, 5 hp, 208-230 Volt, 60 Hz pump control
401220992	STP-CB5G three-phase control box, 120 Volt relay, 5 hp, 460 Volt, 60 Hz pump control
401220932	STP-CBB5H three-phase control box, 220 Volt relay, 5 hp, 575 Volt, 60 Hz pump control

Part Number	Description
401222001	STP-CB5 heater, three required per control box
401222004	STP-CB3 heater, three required per control box
401222003	STP-CBB5H heater, three required per control box
401222012	STP-CB5G heater, three required per control box

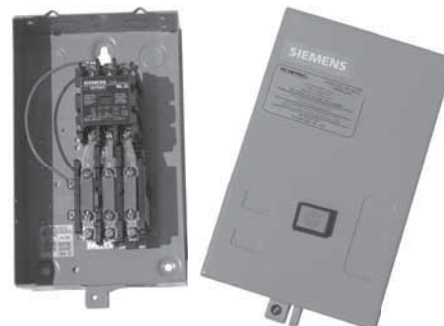

Replacement Pump Motor Assemblies*

Model	Description
PMA3	3 hp 208-230 Volt 6" pump motor assembly
PMA3RJ	3 hp 208-230 Volt 6" pump motor assembly, replaces competitive model UMP300J4-2HB
PMAAG3	3 hp 208-230 Volt 6" AG pump motor assembly
PMA5	5 hp 208-230 Volt 6" pump motor assembly
PMA5RJ	5 hp 208-230 Volt 6" pump motor assembly, replaces competitive model UMP500J4-2K
PMAAG5	5 hp 208-230 Volt 6" AG pump motor assembly
PMA5H**	5 hp 460 Volt 6" pump motor assembly
PMAAG5H**	5 hp 460 Volt 6" AG pump motor assembly
PMA5G**	5 hp 575 Volt 6" pump motor assembly
PMA5GRJ**	5 hp 575 Volt 6" pump motor assembly, replaces competitive model UMP500J6-2K
PMAAG5G	5 hp 575 Volt 6" AG pump motor assembly

Note: Alcohol-gasoline pumps are compatible with fuel mixtures containing any combination of ethanol or methanol and gasoline and 20% MTBE, 20% ETBE or 17% TAME with gasoline.

*For pump motor assemblies with floating suction adapters (3" male NPT connections), specify "F" in the model number and adder charge applies (must be ordered with PMA).

**Please call customer service for lead time on these items.

Syphon System

Item	Part Number	Description
1	402505001	Syphon block
2	400562901	Syphon jet assembly
3	400430004	3/8" P × 3/8" T compression fitting
4	400259001	1/4" pipe plug
5	400114001	1/4" close nipple, two required per system
6	400114003	1/4" nipple × 3" long
7	402510001	1/4" threaded tee
8	402511001	1/4" threaded elbow, 90°
9	400137937	Syphon check valve
10	402544001	Caution tag
11	400982001	Security seal
12	402553902	Copper tube (HC pump)
13	400430003	1/4" P × 3/8" T compression fitting
NS	401165930	Syphon unit complete, includes all items above

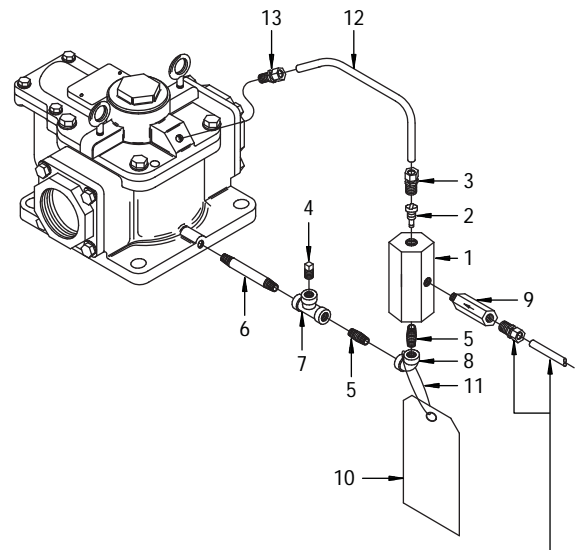

CONNECT 1/4" NPT × 3/8" TUBE FITTING TO CHECK VALVE AND 3/8" OD COPPER TUBING TO HIGHEST POINT IN SYPHON LINE (FURNISHED BY CUSTOMER)

High Capacity General Assembly

Submersible Pumping Systems

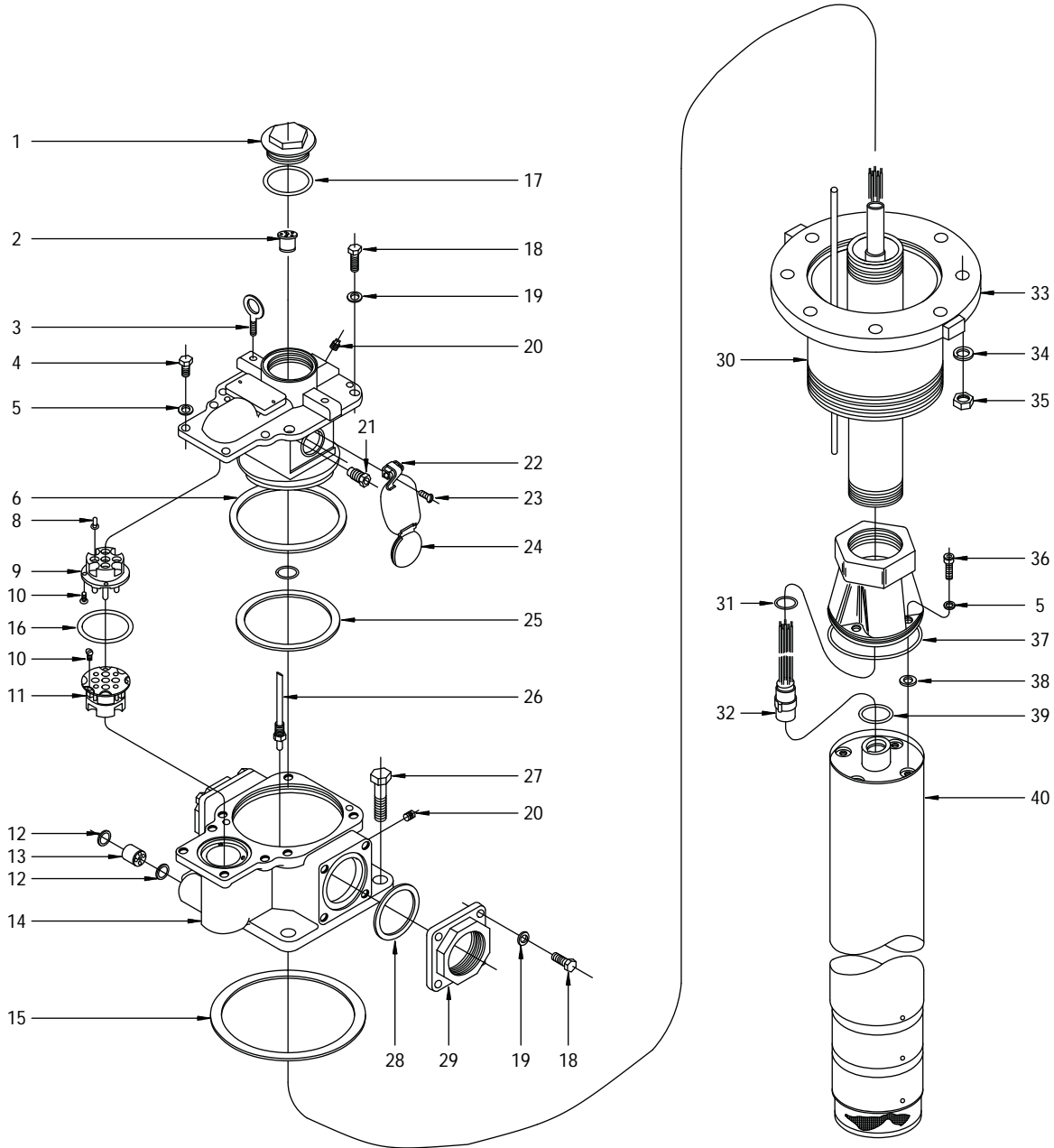

STP3 and STP5 (Tokheim Model 550 6" Submerged Pump general assembly)

Item	Part Number	Qty	Description
1	401148101	1	Connection box cover
2	400236909	1	Seal off plug assembly
3	401149001	2	Eye bolt
4	400258002	4	3/8-16 × 1" large Hex head cap screw
5	400285002	8	3/8" lock washer
6	401236002	1	Upper AG compatible manifold seal
8	400273004	6	12 gauge wire terminal
	400273006	4	14 gauge wire terminal
9	401142901	1	Plug assembly
10	401091001	6	6-32 × 3/8" large round head machine screw, three required per connector
11	401137901	1	Receptacle assembly
12	401238001	2	Bushing ring
13	401239001	1	Seal plug
14	401112101	1	Discharge manifold
15	401163001	1	6" flange gasket
16	400333235	1	AG compatible O-ring
17	400210234	1	O-ring
18	400258005	12	1/2-13 × 1/4" large Hex head cap screw
19	400285005	12	1/2" lock washer
20	400259001	2	1/4" pipe plug
21	401032901	2	Pressure relief valve (old standard relief, tire valve)
	401330901	1	Standard relief (units built since S/N 0302XXXX)
	401330902	1	Model "R" relief (units built since S/N 0302XXXX)
22	401154001	2	Valve spring and bracket
23	400523001	4	10-24 × 3/8" long Sems fastener, two required per bracket
24	401150101	2	Inset valve assembly
25	401236001	1	AG compatible lower manifold seal
26	401158903	1	Air eliminator assembly
27	400258006	4	3/4-10 × 3" large Hex head cap screw
28	401162001	2	3" flange gasket
29	401113101	2	3" companion flange
30	4011910XX 6-5/8" OD × 1/4" WT (XX = length)	1	6" riser pipe 9" riser pipe 12" riser pipe 15" riser pipe 18" riser pipe 21" riser pipe 24" riser pipe 27" riser pipe 30" riser pipe
31	400333218	1	AG compatible O-ring
32	151593906	1	192" lead assembly
33	401161101	1	6" flange
34	400285006	4	3/4" lock washer
35	400274004	4	3/4-10 Hex nut
36	400264011	4	3/8-16 × 1-1/4" large SHCS
37	400333255	1	AG compatible O-ring
38	402406001	4	Rubber washer
39	400333225	1	O-ring
40	PMA XXX	1	Pump motor assembly, includes #37, #39, and four #5, #36, and #38 (XXX indicates options and horsepower)



Distributed by:



FFS-0058 01-10



Franklin Fueling Systems

3760 Marsh Road • Madison, Wisconsin 53718, USA

Tel: +1 608 838 8786 • Fax: +1 608 838 6433

Tel: USA & Canada 1 800 225 9787

Tel: México 001 800 738 7610

www.franklinfueling.com